

# 1. Understanding business activity

## 1.1. Nature of Business Activity

- Needs: goods or services that we need in order to live
- Wants: goods or services which people would like to have. But are not essential for living.
- People's wants are unlimited (you will always want something) but the resources available to produce them are limited which leads to scarcity (the basic economic problem)
- Scarcity: there are not enough products to fulfil the wants of the population
- Resources (also known as factors of production) include: Land, Labour, Capital & Enterprise
  - Land – any natural resource used in production
  - Labour – mental and physical efforts of a human
  - Capital – made-made goods used in production
  - Enterprise – the risk-taking ability of an entrepreneur
- As there are limited resources, people are always forced to make a choice. This means that we will be giving something up, this is known as opportunity cost
- Opportunity cost: it is the next best alternative that is given up by choosing another item.

## 1.2. Specialisation

- **Specialisation:** when people and businesses focus on what they are best at.
- Division of labour is when production is split in different tasks and each worker performs one of these tasks

Advantages	Disadvantages
Workers specialized in certain task, increases efficiency	Workers become bored of doing the same job. Efficiency might fall
Less time is wasted from one workbench to another, more efficiency	If a worker is absent, no other worker can do the job. Efficiency might fall
As the business is more efficient, output increase which may lead to economies of scale	Employees have to rely on each other to produce products, leading to a fall in productivity
Workers become more skilled and experienced, reducing the mistakes made	

## 1.3. Purpose of Business Activity:

- Businesses combine scarce factors of production to produce goods or services to satisfy people's wants

- A business also employs people as worker and pays them wages to allow them to consume products as well

## 1.4. Added Value

- Added value is the difference between the selling price and the cost of bought-in raw materials and components.

*Added Value = selling price – total cost*

- It is NOT the profit because added value does not include the price to pay for labour, transport etc.
- To increase added value, a business can either:
  - Increase the selling price of product, while keeping the total cost of material the same
  - Create a brand image
  - Improve packaging
  - Make products more appealing by adding features
  - Provide higher quality goods and services
- Decrease the total cost of materials, while keeping the selling price of the product the same.

## 1.5. Classification of Businesses

- Businesses can be put into three sectors:
  - Primary sector – extraction of natural resources. Ex. farming, fishing
  - Secondary sector – manufacturing and production of goods. Ex. car manufacturer
  - Tertiary sector – provides services. Ex. hairdressing, banking
- The relative importance of these sectors in an economy depends on:
  - Number of workers employed
  - Value of output produced
- Deindustrialisation occurs when there is a decline in the importance of the secondary sector.
- This can happen due to:
  - Depletion of primary resources in home country
  - Cheaper goods by developing countries
  - Ability to spend more income on services

## 1.6. Mixed Economy

- Has both a private sector and a public sector.
  - Private Sector: Businesses NOT owned by government, will make own decisions on what and how to produce. The main aim is to make profits.
  - Public Sector: Owned by the government. Government will make decisions on what and how to produce (i.e. healthcare, education, defence, public transport). The main aim is to provide a service to customers.
- Privatization refers to the selling of a public sector business to the private sector.
- Privatisation may occur as private sector is more efficient, competitive and will be able to make good quality goods

leading to higher profits.

- But private sector does not have social objectives, making their products unaffordable.

### 1.7. Enterprise, Business Growth & Size

- An **entrepreneur** is a person who organises, operates and takes risk to make the business better
- Characteristics of entrepreneurs:
  - Hard working
  - Risk Takers
  - Creative
  - Effective Communicators
  - Optimistic
  - Self-confident
  - Innovative
  - Independent.
- Advantages and disadvantages of being an entrepreneur:

Advantages	Disadvantages
Independent, able to choose how to use time and money	entrepreneurs will have to put their own money into the business.
Able to put own ideas into practice	many entrepreneur's businesses fail (risky)
May become successful and very profitable if business grows	Lack of knowledge and experience in starting and operating a business
Able to make use of personal interests and skills	Lost income from not being employee for another business (Opportunity cost)
Profits to themselves, no need to share them with anyone	Will have to invest their own savings as well as find other sources of finance , which is time taking and expensive

Who needs to know the size of a business?

- Investors
- Government
- Competitors
- Workers
- Bank

### 1.8. Business Plans

- A business plan contains business objectives, important details about the operations, finance, and the owners
- Business plans assist entrepreneurs because:
  - It helps gain finance. banks will ask for a business plan before agreeing to a loan or overdraft for the business
  - It forces the entrepreneur to plan ahead carefully, which reduces risk of the business failing.
- The main parts of a business plan include: name, type of organization, business aim and forecast profit

### 1.9. Government Support for Start-Ups

- Governments encourage entrepreneurs to set up a business because start-ups:
  - **Reduce unemployment**, new businesses create jobs
  - **Increase competition**, gives consumers more choice
  - **Increase output**, economy benefits from increased output of goods and services
  - Can **grow further** and become large and important businesses which pay government more taxes
- Governments may give support to entrepreneurs by:
  - **Business ideas & help**, they set up support sessions held by experienced business people
  - Finance, they may lend **loans** at low interest rates or **grants**
  - Governments provide grants for **training employees** to make them more efficient and productive
  - Governments allow entrepreneurs to use **research** facilities in universities

### 1.10. Business Size

- There are several different measurements of business size and they all have limitations:

Measurements	Limitations
The number of people employed in the business	Some businesses employ few people but produce high output values
The value of output of the business	high level of output does not mean business is big
The value of sales	different businesses sell different products (expensive and cheap)
The total value of capital (money) invested into the business (capital employed)	some companies may use cheap labor giving low output with low-cost equipment

- No way of measuring the size is considered correct as each method gives different answers. Businesses choose the method they think is the best. Therefore, businesses may use more than one method.

### 1.11. Reasons for business Growth

- Some businesses want to grow because:
  - Higher profits
  - More status for owners and managers
  - can benefit from **Economies of Scale** (lower costs)
  - Larger share of its market, 'big names'

### Ways of business growth

- Businesses can either grow by:
  - Internal Growth
  - External Growth

- Internal Growth is when the business expands its existing operations
- External Growth is when the business takes over or merges with another business.
- There are three types of External Growth:
  - Horizontal Integration – firm taking over/merging with another firm in the same industry
    - Ex. a paper company taking over another paper company
    - Benefits include economies of scale and higher market share
    - Problems include diseconomies of scale and difficult to control and manage the business
  - Vertical Integration – firm taking over/merging with another firm in same industry but different stage of production (there is forwards and backwards)
    - Ex. paper manufacturing company taking over paper selling company
    - Benefits include profits by supplier/retailer are absorbed and personal attention is given
  - Conglomerate Merger - firm merging/taking over another firm in a different industry. (also known as 'diversification')
    - Ex. paper company taking over a food company
    - Benefits include spread of risks and transfer of ideas.

### Why small businesses are at greater risk

- Established by youngsters who lack managed experience
- Borrow money to begin so will have to repay whether or not business is successful
- Start-ups have lesser experience and information about the market in order to make informed decisions
- New entrepreneurs may not have a realistic picture of the market

### 1.12. Why Businesses Fail

- **Poor management** – from lack of experience, poor choice of managers (family business), bad decisions
- **Failure to plan for change** – businesses need to adapt everchanging business environment. Must take risks.
- **Poor money management** – lack of money to pay workers, suppliers, landlords, etc.
- **Over-expansion** – (diseconomies of scale), management problems and finance
- **Competition with other businesses** – new businesses are at more risk of failing than existing businesses.
- This is because start-ups have lack of money, resources, poor planning & don't have much research

### 1.13. Sole Trader

- A business owned by just one person. It's the smallest type of business. Can employ other people however.
  - Useful for people who are setting up new business
  - Do not need much capital to get business running
  - Will be dealing mainly with the public

Advantages	Disadvantages
Easy to set up, do not require a lot of money to set up	Capital is usually provided by owner, hard to get capital to expand firm
They are their own boss, has the freedom to choose their own holidays, work hours, prices, who to employ	They have unlimited liability (responsible for any debts of the business, bank can take away possessions to pay back)
Close relationship with customers	Business is likely to remain small
Does not have to share profits	No one to discuss business matters with
Does not have to give information about the business	They are unincorporated (business has same identity as the owner). So, business ends when owner dies
Lesser legal restrictions	

### 1.14. Partnerships

- A business in which 2 to 20 people agree to own it. Usually small businesses but bigger than sole traders.
  - Useful for people who want to form a business but don't want the legal complications
  - Industries such as medicine or law where you are not allowed to form a company
  - Partners that know each other very well
- Requires a **Partnership Agreement**

Advantages	Disadvantages
Easy to set up, do not require a lot of money	Capital is usually provided by partners
More capital invested (more expansion)	Partners have unlimited liability
Partners are motivated because any losses are shared by the partners	Partners can disagree on decisions. If one of the partners is inefficient, they all lose money
Responsibilities are shared (focused on different parts of business)	They are unincorporated. If one of the partner dies, the partnership ends

- **Contents of Partnership Agreement:**
  - Amount of capital invested by all partners
  - Tasks to be done by each partner
  - The way profits are shared out
  - How long partnership will last

- Arrangements for absence, retirement and how partners could be let known

### 1.15. Private Limited Company (LTD)

- An LTD is different from the other because it can sell **shares** and it is an **incorporated** business.
- Company must be owned by at least 2 **shareholders**
  - A **shareholder** buys shares of an LTD company which represent part ownership of the company
  - **Dividend** is the amount of profit each shareholder gets
- Shares are sold **privately** to friends and family
- Has separate identity from owners, incorporated, so company accounts are separate from the owners'
- Must have: **Articles of Association** and **Memorandum of Association**
- **Article of Association** – must contain the **RULES in which the company will be managed**. Contains:
  - Rules for shareholder meetings
  - List of directors and their jobs
  - Voting rights of shareholders
  - Details of how accounts are recorded
- **Memorandum of Association** – must **contain important information about the company**:
  - Company name, address
  - What the business does
  - Number of shares to be sold

Advantages	Disadvantages
Shares can be sold to lots of people. More capital to expand	Difficult to set up (legal formalities).
Owners are able to keep control of company as long as they don't sell too many shares	Shares are difficult transfer. Requires other shareholders to agree
All shareholders have limited liability (bank can only take amount of money invested)	Accounts are less secret than other forms of business
Company continues after a shareholder dies	Company cannot offer it shares to the public

- Private Limited Companies are useful for family businesses or businesses/partnerships where owners want to expand more (as you can sell shares)

### 1.16. Public Limited Company (PLC)

- A PLC is similar to LTD only the shares can be sold to the **public**. It is the biggest type of business.
- Shareholders of PLCs may attend an **Annual General Meeting** where they may vote for the board directors

Advantages (in addition to those in LTDs)	Disadvantages
-------------------------------------------	---------------

Advantages (in addition to those in LTDs)	Disadvantages
Opportunity to raise high capital sums	Difficult to set up (legal formalities) & accounts are even more public
No restriction of buying, selling or transferring shares	Danger of business being taken over due to public shares
	Selling shares to public is expensive

- **DONT GET CONFUSED**, Public Limited Companies are **NOT** in the **PUBLIC** sector, they are in **PRIVATE** sector

### 1.17. Joint Venture

- A joint venture is when two or more businesses start a project together sharing capital risks, and profits

Advantages	Disadvantages
Costs are shared, good for expensive projects	Profits have to be shared if project is successful
Shared knowledge of two businesses	Might have disagreements over important decisions
Risks are shared	Different methods of running business

### 1.18. Franchise

- A franchise is an agreement of a business based upon an existing brand/business
- The **franchisor** is the main business/brand
- The **franchisee** is the individual to start up franchise
- In a franchise, the franchisor allows the franchisee to trade under its name and see its products for a fee
- The franchisee pays an original fee to franchisor and a percentage of its profit for the privilege
- Franchisor provides support, such as:
  - Advertising
  - Legal advice
  - Employee training
  - Financial advice
- Franchise agreements last 5 – 20 years, if franchisee cancels the agreement early there may be large fines

### 1.19. Risk, Ownership & Limited Liability

- **Risk** - the uncertainty of profits or danger of loss, events that could cause business to fail
- **Ownership** – who owns the business (partnership = partners, LTDs and PLCs = the shareholders)
- The people with risk are usually the owners
- **Liability** – how much the shareholders of a company are liable for the debts in the business



- **Limited Liability** – liability of shareholders is limited to the amount of money they invested (PLC & LTD)
- **Unlimited liability** – owners of business are held responsible for all the debts of the business (not just their investment) (Sole trader & partnerships)

### 1.20. Public Sector

- The public sector includes every business owned by the government.
- Businesses in the public sector are public services, i.e. education, transport, hospitals, education and police
- Usually these businesses have been **nationalized** (used to be private sector but government bought it)
- Capital comes from taxes, by tax payer

Advantages	Disadvantages
Reduces wastage of resources (if a monopoly)	Low efficiency due to lack of competition
Allows access of essentials to everyone	Easily manipulated by the government to exploit citizens
Continued even if in losses	Not flexible as profit is not a main aim
Keeps in mind social costs of decisions (non-profitable)	Will have to be subsidized if in losses, opportunity cost

### 1.21. Business Objectives

- **Business objectives** are aims or targets a business works towards
- Benefits of having business objectives:
  - Employees have a clear target to work towards
  - Decisions made keeping in mind objectives
  - Clear & measurable objectives will make sure the entire organisation works towards the same goal
  - Managers will be able to compare performance
  - A business objective maybe changed if economic conditions change or one objective has already been achieved
- Private sector business objectives:
  - **Business Survival** - Adjust to business environment, change price of products if necessary
  - **Generating profit** – pay a return to owners or provide finance to invest further in business
  - **Returns to shareholders** - discourage shareholders from selling their shares. Can be increased by increasing profit or increasing the share price
  - **Growth of business** – increase salaries, economies of scale. only achieved if customers are satisfied with the product
  - **Market Share** – the proportion of the total market sales by one business, gives good publicity, more influence over suppliers and customers
  - **Service to community** – provide jobs, support disadvantaged groups in society, protect environment

### 1.22. Stakeholder objectives

- A **stakeholder** is any person with a direct interest in the performance of a business
- There are two types of stakeholder groups:
  - **Internal Stakeholders** work/own the company (owners, managers, workers)
  - **External Stakeholders** are outside of the business (consumers, government, banks)
- Each stakeholder group has different objectives for the performance of the business
- **Internal Stakeholder's** objectives are payments or profits, they want business growth, so value of investment increases or they get higher status/power
- **Customers** objectives are reliable products, value for money, good quality, good design and good service
- **Government** objectives include: money from taxes, will employ more people, increase country's output
- **Banks** objectives are to make profit out of loans
- Since different stakeholders have different objectives, it may cause conflict, to try to please all the stakeholders
- For example: customers want cheap products but workers want higher salaries.
- Therefore, managers have to compromise to decide which objectives are best for the company

## 2. People in business

### 2.1. Motivating Workers

- It is very important for a business to have a well-motivated workforce
- The main reasons why people work:
  - **Money:** to pay for the basic needs for life and some wants
  - **Security:** to know that you are safe (financially)
  - **Affiliation (Social needs):** to feel part of a group, meet people, make friends
  - **Self-importance (esteem):** to feel that you are important and that the job you do is important
  - **Job Satisfaction:** to feel pleasure that you have done a good job
- **Motivation** – the feeling that makes employees want to work hard and effectively in a business
- Well-motivated workers high productivity increased output higher profits
- Unhappy workers do not work effectively low output no/ lower profits

### 2.2. Key Motivational Theories

- F.W. TAYLOR
  - "All individuals are motivated by personal gain"
  - Also known as "theory of an economic man"
  - Had a mechanical approach rather than human.

- This means that if the workers are paid more, they will work more effectively
- By breaking down worker’s jobs into simple tasks, you could calculate how much output they could do in a day
- Taylor’s idea was that if the workers produced more, they would receive a bonus
- But the problem with this approach is that Taylor believed everyone is ONLY motivated by money, which doesn’t, always stand true
- ABRAHAM MASLOW
  - Also known as “Hierarchy of Needs” – a pyramid showing the different types of needs and how some are more important than others



- Physiological Needs – food, rest, shelter (fulfilled by receiving wages)
- Safe/security Needs – protection against danger & poverty. Having fair treatment (fulfilled by having job security)
- Social Needs – friendship, belonging in a group (fulfilled by having colleagues at work)
- Esteem Needs – having status and recognition (fulfilled by being recognised for good work)
- Self-actualisation – achieving your full potential, feeling that you have done a good job (fulfilled by being promoted & being given more responsibility)
- Maslow’s theory also suggests that each level in the hierarchy (starting from Physiological needs) needs to be achieved before moving on to the next
- FEDRICK HERZBERG
  - Also known as “the 2-factor theory”
  - Humans have two sets of needs:
    - Basic animal needs (called ‘Hygiene’)
    - To be able to grow physiologically (called ‘Motivator’ needs)

‘Motivator’ Factors	‘Hygiene’ Factors
Achievement	Status
Recognition	Security
Personal Growth	Work Conditions
Advancement/Promotion	Relationship with boss & subordinates
Work itself	Salary

- The presence of hygiene factors doesn’t motivate employees, but their absence demotivates them.

### 2.3. Methods of Motivation

- There are 3 Factors that motivate employees:
  - Financial Rewards
  - Non-Financial Rewards

- **Job Satisfaction**
- Financial Rewards/Motivators include:
  - **Wages**
    - Wage is a payment given weekly
    - Workers are paid quickly, so don’t have to wait too long to receive money
    - Given overtime for extra hours worked
    - They must be calculated every week, which is expensive
    - Wage clerks need to be appointed
  - **Time Rate** (payment per hour, i.e. 10\$/hour)
    - Paid according to number of hours worked
    - Easy to calculate
    - Good and bad workers are paid the same (demotivating)
    - Supervisors may need to be appointed to keep a check on workers
    - Clocking-in system may be required
  - **Piece Rate**
    - Workers are paid depending on the quantity of products made
    - Given above basic pay
    - Encourages workers to work faster
    - May only focus on quantity and ignore quality
    - Workers focusing on quality may earn less (demotivating)
  - **Salaries**
    - Paid monthly
    - No overtime
    - Salary = annual income/12
    - Payment needs to be calculated only once a month
  - **Commission**
    - Given to sales staff
    - Higher sales, higher money
    - Encourages people to sell more
    - If too persuasive may have negative effects on customers
  - **Profit sharing**
    - It involves giving employees a share of profit, above basic pay
    - Increases motivation
    - Other profits may be given to shareholders
  - **Bonus**
    - A lump sum amount of money is given to workers who have done a good job
    - Paid yearly
    - Performance related pay
    - Employee pay is related to the effectiveness of the employee
    - Mostly used in service sector, when output can’t be easily measured
    - Often used as a method of appraisal
    - Appraisal is when an employee’s immediate supervisor observes their work and discusses their training needs
  - **Share ownership**
    - Shares of a company are given out to employees

- Encourages them to work harder
- Share price and value may increase
- Improves loyalty as there's a greater sense of belonging
- Non-Financial Rewards (fringe benefits) -
  - Company Car
  - Discounts of products
  - Health Care
  - Children's school paid for
  - House is paid for
  - Free trips abroad (holidays)
- Job Satisfaction
  - Enjoyment derived from feeling that you have done a good job
  - Pay
  - Promotion
  - Status
  - Training
  - If these things are kept in mind employees will be well-motivated
- Job Rotation
  - Working, swapping around and doing a specific job for a limited time period
  - Increases variety of work
  - Easier for managers to cover up if 1 employee is absent
  - Makes the job more interesting
- Job Enlargement
  - Where extra tasks of similar level of work are added to a person's job description
  - Extra tasks shouldn't add extra work
  - Increases variety
  - Higher job satisfaction
- Job Enrichment
  - It involves adding tasks that require more skills
  - Higher responsibility
  - Higher job satisfaction
  - Higher productivity

## 2.4. Organisation and Management

- **Organisational structure** – the levels of management and division of responsibilities within a company
- Organisational Charts show a clear structure of the business and make it easy to see which part of the company does what
- Features –
  - It is a hierarchy
  - Organised into departments
  - Shows the chain of command and span of control
- Benefits –
  - The chart shows how everybody is linked in the organization
  - Gives a sense of belonging
  - Employees know their position
  - It shows how departments are linked
  - All employees are aware from which communication channel will they receive messages

- Example of Organisational Chart:

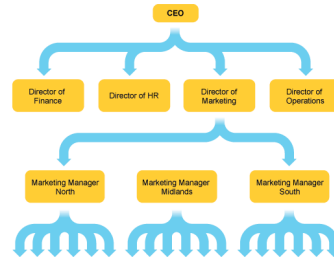

- Chain of command - The structure in an organization which allows instructions to be passed down from senior management levels to lower levels of management
- Span of control - The no of employees working directly under a manager
- There are two types of organizational structures of a business:
  - You can have a **'tall'** structure, with a long chain of command:

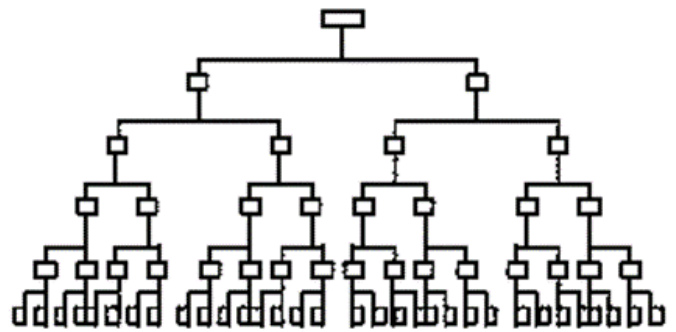

- You can have a **'wide'** structure, with a short chain of command:

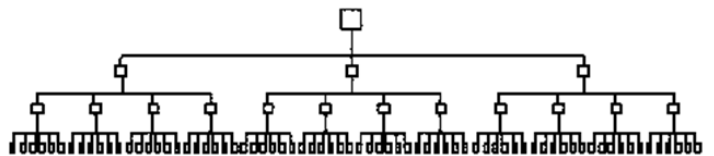

- The advantages to have a short (and wide) structure is that:
  - Communication is faster and more accurate
  - Top managers are more in touch with subordinates because there are less levels
  - Wider span of control means employees feel trusted and take more decisions by themselves
  - Higher job satisfaction
- Disadvantages:
  - Difficult to control
  - Inefficient supervisors
  - Communication problems
  - Difficult to motivate workers
  - Sometimes there may be a conflict between departments (i.e. marketing wants to buy something but finance does not think it is necessary)
- The supervisors working in these departments are Line managers – they have direct responsibility over people below them in the organisational chart

- You also have **Staff Managers** – which are specialists in certain areas to provide support and information to line managers

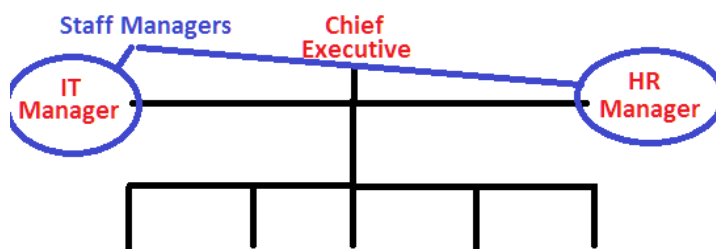

## 2.5. Role of Management

- All organisations have managers. Leaders, director, executive are all different names, but they are all managers
- The functions of managers include:
  - Planning** – setting aims or targets
  - Organising** – delegating tasks. organising people and resources effectively
  - Co-ordinating** – making sure departments work well with each other and have good communication
  - Commanding** – making sure the workers are keeping to targets and deadlines. By guiding and delegating tasks
  - Controlling** – measuring and evaluating work of employees and verify they are on target
- Without clear and effective management, a business will lack:
  - A sense of control and direction
  - Control of employees
  - Organization of resources
  - Coordination between departments

## Delegation

- Delegation involves giving a subordinate the authority to perform particular task.
- However, if the employee does a bad job, the manager must accept the responsibility for it
- Delegation is important because:
  - Managers cannot do every job by themselves
  - Managers can then measure the success of the employees
  - Work becomes more interesting for subordinate, increases their motivation
  - Makes employees feel trusted and important
  - Gives workers greater career opportunities and chances of promotion
- However, some managers do not delegate tasks because:
  - They might be afraid the subordinates will fail and manager wants to control everything
  - Manager might also feel threatened that subordinate will do a better job than them
- Delegation means that once the task is completed, the manager will have less direct control

- This means the trust for the workers is increased by the manager
- Therefore, there needs to be more trust in workers in order to reduce control over them

## 2.6. Leadership Styles

- Leadership styles are the different approaches to deal with people when with authority
- There are THREE TYPES OF leadership styles:
  - Autocratic Leader:** where the manager expects to be in charge of the business and expects to have their orders followed with no questions asked
  - Democratic Leader:** where the manager allows the subordinates to be involved in the decision-making process
  - Laissez-Faire Leader:** Where the manager makes broad/general objectives for the employees and leaves them to make their own decisions.

## 2.7. Trade Unions

- Trade union** – a group of workers that join together to protect their interests
- A trade union is a pressure group
- Employees usually have the same interests (i.e. good wages, pleasant work environment, etc)
- If an employee wants to join a trade union, they must pay a yearly subscription for the benefits
- Benefits from a trade union usually include:
  - Improved conditions of employment** (such as wages, holidays, hours of work)
  - Improved work environment** (health & safety, heating, noise)
  - Advice/support** if member thinks they have been unfairly fired, mistreated, etc
- Disadvantages:
  - Costs money
  - May required to take industrial action

## 2.8. Recruitment

- Recruitment** – the process from identifying that a business needs to employ someone, to the point where applications have arrived at the business
- Recruitment is one of the roles of the Human Resources department
- Recruiting usually happens when an employee leaves a job, a business is starting up, or it wants to expand
- Recruitment process (for external recruitment):
  - A **job analysis** is done to identify the tasks and responsibilities to be carried out by the new employee
  - Once the details of the job are gathered, a **job description** will be made, outlining these duties.
  - From the job description, a **job specification** is created, which outlines the requirements, qualifications and expertise for the job

- Then the **job is advertised**
  - Internal - when the vacancy is filled by someone who is an existing employee of the business
    - It is cheaper, motivates other employees, potential of the employee is already known. The employee is aware of the working conditions and other workers, lesser time taken for induction training
    - But no new ideas come into the business and there may be jealousy and rivalry amongst employees
  - External - when the vacancy is filled by someone who isn't an existing employee and will be new to the business
    - New ideas come into the business. There's wider choice of workers
    - But it is expensive and time-taking and may demotivate existing employees
    - Ads can be place in:
      - Local newspapers- usually for unskilled and semi-skilled workers.
      - National newspaper- usually for senior positions which requires high skills.
      - Specialist magazines- used for particular technical people.
      - Government job centers- usually for unskilled and semi-skilled workers.
      - Recruitment agencies- they keep details about qualified people and are approached by companies
- Selection process:
  - Candidates start by sending their application forms. They send in their CV's and resumes outlines why the applicant wants the job
  - Short-listed applicants are called for interviews. These may be done one-on-one, two-on-one talks, skill tests, aptitude tests, etc.

## 2.9. Types of Workers

- Part-time workers
  - Workers working for less than 35 hours a week
  - Advantages:
    - Work hours are flexible.
    - Business can extend the opening/closing hours
    - Employees can just work at busy times
    - Cheaper for the employer than employing a full-time worker
    - May agree for a low salary as good work-life balance
  - Disadvantages:
    - Employees are less likely to be trained because they might see it as temporary and don't want a promotion
    - Takes longer to recruit many part-time workers than a couple full-time workers
    - Communication problems may arise
    - Might be less committed to the company

- Full-time workers
  - Workers working for more than 35 hours a week
  - Advantages:
    - Higher training and chances of promotion
    - Lesser time taken in recruitment
    - Highly committed to the business
    - Lesser communication problems
  - Disadvantages:
    - No flexible working hours
    - Expensive
    - May demand higher pay as poor work-life balance

## 2.10. Training

- Training is needed when:
  - New technology is employed
  - Less supervision is required
  - Need to increase efficiency
  - Need to increase chances of internal promotion
  - New skills needed
  - Need to lower accidents
- There are three types of training:
- **Induction Training** – where the employee is **given an introduction** on the company's **procedures and customs**, and is **introduced to their co-workers**

Advantages	Disadvantages
Employees settle into their job quickly	Time consuming
Workers make fewer mistakes	Worker is being paid while not doing work
May be a legal requirement	Delays the start of work for the employee

- **On-the-job Training** – where the **employee does the job while being supervised** by a more experienced worker, giving tips, suggestions and help

Advantages	Disadvantages
Employee does not need to be sent away	Trainer won't be as productive because they are teaching employee
So cheaper than off-the-job training	Trainer might have bad habits and pass on to employee
There is still production from worker while training	Not recognized training qualifications outside the business

- **Off-the-job training** – where the **employee is trained away from the workplace**, normally by specialized trainers.

Advantages	Disadvantages
Lots of skills are taught	Expensive to send employees off to expert trainings



Advantages	Disadvantages
trainings are sometimes off-work hours, worker will still work	Workers are being paid but not doing any work
Employees become versatile (can be moved around company and know what to do)	Professional training gives employees additional qualifications, makes it easier for employee to find another job

- Sometimes, a company might need to **reduce the size of the workforce**, possibly because of:
  - **Automation** (robots replacing human jobs)
  - **Less demand** for products or services
  - Business might have **relocated abroad**
  - Business being **taken over/merged** and now there are **too many workers** doing same job
- Companies need to think ahead on the future and establish how many employees they will need and their skills, this is called **workforce planning**
- When a business needs to reduce the number of employees, they can either **dismiss** the employee or make them **redundant**
- **Dismissal** – when the worker is told to **leave the job** due to **poor work or poor behavior** (i.e. if employee is always late for work after being given warnings, when employee is caught stealing, etc)It is more commonly known as being **'fired'**
- **Redundancy** – when a business no longer needs an employee. Even though the employee did nothing wrong. Usually happens during period of falling sales or due to an economic recession (when no one is buying anything)

### 2.11. Legal Controls over employment issues

- There are many laws in countries, that ensure that everyone has equal employment opportunities regardless of race, gender, religion, age etc.
- This means that businesses need to be careful when advertising a job. They cannot advertise for just a single type of person.
- Companies must treat all applicants for the job equally, if not, they will be fined and prosecuted
- Employees of a business have legal right that must be protected, which includes:
  - **Unfair discrimination at work/when applying:** i.e. when employers discriminate unfairly against employees or applicants due to their race, gender, religion or colour.
  - **Health and safety:** there are laws that make sure that employees are protected from dangerous machinery, that they are provided safety equipment & clothing, hygiene conditions, suitable temperatures, provide breaks.

- **Unfair dismissal:** when the worker is dismissed unfairly (i.e. from joining a trade union, being pregnant, or when given no warnings before being dismissed), the worker can take their case to an **industrial tribunal** to see both sides of argument.
- **Wage protection:** an employee in a business should have a **contract of employment**, where it should contain the wage rate, frequency of wages and what deductions are made from the wages (from tax). In some countries businesses pay whatever they want because unemployment is high, so they offer very low wages.  
Governments take action by creating a **legal minimum wage**.

### 2.12. Internal & External Communication

- Effective communication is important so that the information sent in the message is received, understood and acted upon as it should
- It is important to businesses because if it is not understood, it can lead to serious consequences
- There are two types of communication in businesses:
- **Internal Communication** – communication between employees of the same business
- **External Communication** – communication between the business and other businesses and individuals
- External communication has to be especially efficient because it establishes the image and the efficiency of a business
- i.e. if a company communicates inefficiently with their suppliers, they might receive the incorrect materials
- Effective communication involves:
  1. The **transmitter**/sender sending a message to pass on information
  2. A **medium of communication** – the method for sending message (i.e. e-mail, phone, etc)
  3. The message being sent to the **receiver**
  4. The receiver confirming that the message has been received and responds to it (**feedback**)
- There are two types of communication:
  - **One-way communication** – where the receiver cannot reply to the message (i.e. posters)
  - **Two-way communication** – where the receiver can respond to the message, could be just confirmation that message was received (e-mail)
- The methods of communication include:
- **Verbal methods** – sender speaks to the receiver (i.e. meetings, telephone, video conference)

Advantages	Disadvantages
Information given out quickly & Efficient way to communicate with many people	If talking to many people, it's hard to tell whether everyone got the message

Advantages	Disadvantages
Opportunity for immediate feedback	Not good for accurate messages and if a permanent record of the message is needed
Message is reinforced by the speaker's body language	

- **Written methods** – sender creates e-mails, memos or letters, including the use of Information Technology

Advantages	Disadvantages
Message can be referred to in the future "hard evidence"	Might lead to too many e-mails and 'information overload'
Easy to explain complicated messages	Two-way communication is difficult
Can be copied and re-sent to many people	Hard to check if message has been received

- **Visual methods** – sender uses diagrams, charts, videos, PowerPoints

Advantages	Disadvantages
Information presented in more appealing way, people will be more interested to look at it	No feedback and needs other methods of communication to go with it
Can be used to make written messages clearer, to illustrate the point	Graphs and charts may be difficult for people to understand, message may be misunderstood

### 2.13. Communication Barriers

- **Communication Barriers** – things that prevent efficient communication
- **Problems with the sender:** when language is too difficult, speaks too quickly/not clearly, communicates wrong message
- **Overcome by:** using understandable language, making sure message is as clear as possible by asking questions to make sure message was understood
- **Problems with the medium:** message may be lost/not seen by receiver, wrong medium used (i.e. important message on noticeboard), if message is being passed along – it might get distorted
- **Overcome by:** sender asking for feedback/receiver always sending feedback that message is received, selecting the appropriate channel to send message
- **Problems with the receiver:** not listening/paying attention, receiver doesn't trust the sender/doesn't want to do it
- **Overcome by:** emphasizing importance of message, ask for feedback to ensure it was understood, using direct communication

## 3. Marketing

### 3.1. Marketing, Competition & Customer

- **Marketing** – Identifying customer needs and satisfying them
- There are many departments within the Marketing sector of a business
- The role of the marketing is to:
  - **Identify customer needs** – this will be done via 'Market Research'. It will influence the development of a product, its price, and the sales technique
    - A good marketing department should also be able to anticipate (predict before happening) changes of customer needs (i.e. due to advancement in technology)
    - Find new trends or gaps in market with potential
  - **Satisfy customer needs** – selling the exact product customers want, for a price they are willing to pay
  - **Maintaining customer loyalty** – building customer relationships and make sure that existing customers will continue to buy from them and to attract new customers
    - Maintaining customer loyalty will be achieved by always satisfying customer needs
  - **Gain information about customers** –
    - They need to gain information about the changing needs of the customers.
    - They need to understand why customers buy their products and how they use them.
  - **Anticipate changes in customer needs** –
    - Identify new trends in customer demands or gaps in the market.
- Markets change because **consumer spending patterns change**, this might be due to:
  - **Trends and fashions change** – for a period of time it might be fashionable to have a specific product (i.e. Fidget Spinner) but a month later no one buys them
  - **Advancement in technology** – new products provide the latest technology so older versions (i.e. iPads or computers) don't have high sales
  - **Unemployment/Wages** – Economies with high unemployment rates/low wages will not have high sales of expensive products
  - **Ageing population** – different ages are interested in different products (i.e. anti-ageing creams)
- Changing customer needs are important to businesses. They must identify these changes and respond in order to stay successful
- Some markets have become **more competitive** because:
  - **Globalization** – products are sold all over the world
  - **Transportation** – it is cheaper, quicker and easier to send products around the world now
  - **Internet** – customers can now search for products or services and buy from somewhere else around world
- For a business to stay competitive, it must:

- Maintain good customer relationships
- Keep improving its existing products
- Bring out new products to keep customer's interest
- Keep costs low

### 3.2. Market

- **Market** – the total number of customers, potential customers and other sellers of a product/service
- There are two types of market:
  - **Mass market** – where there is a very large number of sales of a product type

Advantages	Disadvantages
Sales are very high	Lots of competition
Can benefit from economies of scale	High costs of advertisement
Opportunities for growth (large sales)	Many similar products so it may not meet specific needs of all customers
There are many variations of products so risk is spread	

- **Niche market** – a SMALL (usually specialized) segment (part) of a mass market

Advantages	Disadvantages
Avoid competition with big businesses	Small – limited number of sales
Specific needs of customers are focused. Advantage over mass market	Usually specialize in just one product, if product has low demand, it will fail

- For example, the tie industry is a mass market, but a business that makes ties out of crocodile skin is a niche market

### 3.3. Market Segmentation

- **Market segments** – a sub-group of a market in which the consumers have similar characteristics or preferences
- A market can be segmented by:
  - According to **age**
  - **Socio-Economic** group – grouping people according to how much they are paid
  - **Location** – where people live (people that live in wet areas will buy more waterproof clothing than those who live in dry areas)
  - **Gender** – men and women products differ
  - **Lifestyle** – how many children a person has, religion, habits, etc.
- **Benefits of market segmentation:**
  - Business aims all of its marketing efforts to the specific segment, making marketing costs efficient
  - Since less money is spent on marketing, more profit

- Identify a market segment whose needs are not being fully met and fill the gap (first in market)

### 3.4. Market Research

- There are 2 types of businesses:
  - **Product-oriented business** – a business that focuses mainly on the product itself
  - **Market-oriented business** – a business that focuses on market research and find out what the customer wants **BEFORE** a product is developed
- Market research is important because a business needs to know how many people would be willing to buy the product, this is to see how profitable it would be
- **Market Research** – gathering information about consumers' needs or preferences in a market
- There are 2 main types of market research:
  - **PRIMARY RESEARCH (field research)**
  - **SECONDARY RESEARCH (desk research)**
- **Primary Research** - Gathering of ORIGINAL data by talking directly with customers/potential customers
  - Process:
    - Purpose of market research
    - Decide on the most suitable method of market research
    - Decide the size of sample and who is going to be asked?
    - Carry out the research
    - Analyze the data and results
    - Summary of the research
  - Primary research includes:
    - **Questionnaires**
      - They may be conducted face to face, by telephone, internet.
      - Online surveys may also be carried out.
      - Advantages:
        - Detailed qualitative information can be gathered.
        - Customer's opinion can be obtained.
        - Online surveys may be cheaper and easier to collate the results.
        - They can be linked to prize draws and encourage people to fill them.
      - Disadvantages:
        - If not filled properly, may mislead the business as there may not be accurate answers.
        - Lots of time and money needed.
        - Collating and analyzing data also need a long time
    - **Interviews** – person will interview other person and ask questions
      - Advantages:
        - The interviewer will be able to explain the questions if not understood
        - Detailed information about the interviewee can be gathered
      - Disadvantages:

- The interviewer may lead the interviewee to answer in a certain way
- Time consuming
- Expensive
- **Samples** – A group of people who are selected (randomly) to answer (i.e. questionnaire)
  - When deciding who to ask to fill a questionnaire or who to interview, a sample would have to be selected. It can be
  - A random sample – It means that every member of the population has a chance to be selected. They are selected at random. Everyone has a chance to be picked.
  - A quota sample – People are selected on the basis of certain characteristics. They are able to find out views of a specific group.
- **Focus Groups** -
  - It is where groups of people agree to provide information about a specific product.
  - It will help sales and development.
  - These groups may even test a product explaining the likes and dislikes
  - Can provide detailed information
  - Time consuming
  - Expensive
  - May be biased
- **Observations** –
  - Most inexpensive way of gathering information.
  - Gives only basic figures
  - Doesn't include reasons for the choices
  - It can be in the form of:
    - Recording
    - Watching
    - Audits
- **Secondary Research** –
  - Information that has already been collected and is available for others
  - This information can be obtained either from **INTERNAL SOURCES** or **EXTERNAL SOURCES**.
  - **Internal Sources** – within the firm's own records: sales departments, customer records, finance department and CUSTOMER SERVICE department
  - **External Sources** –
    - Government statistics - a detailed source of general information
    - Newspapers - useful articles about the general economy state
    - Trade association - information about business in the industry
    - Market research agencies - specialist agencies who carry out the research on company's behalf where in commission is paid
    - Internet - easily accessible source. Paper based sources can also be found

Benefits	Limitations
----------	-------------

Benefits	Limitations
Cheaper than primary as research has already been done by others	You do not get specific results for a certain product or service, you get broad results
There is some information (i.e. economic forecasts or population size) that can't be obtained by primary research	Data may be outdated or incorrect as it was collected by others
	Might not have the specific information

- Regardless on which type of research a business chooses to use, the accuracy of the research data depends on:
  - How **carefully** the **sample** was drawn up
  - How the questions in questionnaires/interviews were **written** to make sure **honest answers** were given
  - The **sample itself** and its **size**. By using **quota** sampling you might get more reliable results
  - **The bias** – some secondary research will be biased (i.e. articles on newspapers) which means the information might be unreliable
  - **Age of the data** – older data might be inaccurate

### 3.5. Marketing Mix

- **Marketing Mix** – all of the activities that are involved when marketing a product or service
- The marketing mix can be summed up as the 4 Ps:
  - Product
  - Price
  - Place
  - Promotion
- **You should always mention the 4 Ps when answering question about Marketing Mix!**

### 3.6. Product

- The product is the most important element in the 4 P's
- Most companies are market oriented and spend most lots of money in market research
- Some products are sold to consumers and some to other businesses.
- They are usually grouped:
  - Consumer goods
  - Consumer services
  - Producer goods
  - Producer services
- Different types of goods are marketed, produced and developed in different ways.
- Promotion of a consumer goods will be much different than that of a producer good
- Producing the right amount of product is an important part of marketing mix:
  - They need to satisfy customer needs and wants.
  - It must be of right quality and price

- Cost of production must enable a price that is suitable for customers as well makes a profit to the business.
- Design of the product is very important. The quality of the product must match the price.

## Development of new products

- Benefits –
  - USP – unique selling point
  - Diversification
  - Allows business to expand into new and existing markets
- Drawbacks –
  - Costs of carrying out market research and analyzing the findings
  - Cost of producing trial products including waste materials
  - Lack of sales if target market is wrong
  - Loss of company image if the product fails to meet consumer wants

## Importance of brand image

- Selling a product directly to a consumer is much easier and helps them inform customers the products quality.
- Nowadays, mostly manufacturers sell them to retailers who then pass it on to the end consumers.
- To make customers know about the product the manufacturers give their product a unique name, brand name, and advertise relating to the brand.
- Branded products are sold at high rates as they are expected to be of high quality.
- Customers may have brand loyalty if they like the product's quality and price.
- Brand image is very important when attracting new customers.
- A brand will have a whole image which will be reinforced by advertisements.

## Role of packaging

- Having the right packaging is very important as it plays a key role in attracting customers.
- Packaging gives protection to the product and doesn't allow it to get spoiled.
- It allows a product to be easily used.
- It needs to be suitable for transportation.
- It is also used for promotion.
- The color and shape help attracting the customer.
- Labels on products carry vital information.
- It promotes the brand image.

## Product life cycle (PLC)

- First the product is developed. The prototype will be tested in the market. Before its launch. There are no sales during this time.

- Then it is introduced or launched in the market. Sales at first will grow slowly as not everyone is aware about the product. Informative advertising will be used to promote the product until it is well – known.
- Sales will start to grow rapidly. The advertisements change to persuasive ads to encourage brand loyalty. Prices might be reduced at this time as there are competitors. Profits are made and are used to cover development costs.
- Maturity – sales increase slowly. There is high competition and lots of advertisements have to be done. Profits are the highest.
- Saturation - there are stable profits. No new competitors. Competitive pricing is used and prices are reduced. Profits begin to fall as sales reduce.
- Decline – the product is removed out of the market as there are new products introduced and the business might be in losses. Advertising is stopped.

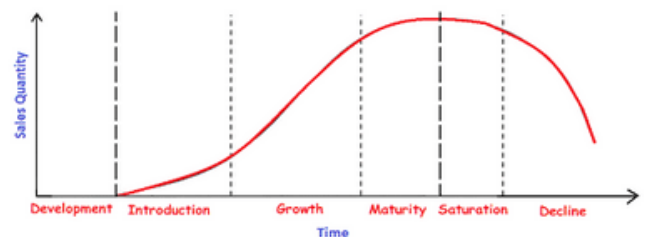

## How stages to plc influence marketing decisions

- Introduction –
  - Product – newly launched product
  - Price – price skimming or penetration pricing
  - Place – limited range of exclusive shop (if price skimming is used)
  - Promotion – informative advertising
- Growth –
  - Product – remains the same
  - Price – raise prices if penetration pricing was used
  - Place – increase the number of outlets, e-commerce
  - Promotion – establish a strong brand identity by promotional activities.
- Maturity/saturation –
  - Product – plans for product changes begin
  - Price – lower prices to competitive
  - Place – full range of distribution channels used
  - Promotion – sales promotion techniques to encourage repeat purchases
- Decline –
  - Product – changes made to extend the life cycle
  - Price – lower prices
  - Place – sell through low-cost outlets
  - Promotion – re launch the product as an extension strategy

## Extending product life cycle

- Introduce new variations into the original product
- Sell into new markets



- Make small changes to the product's design, cover, color
- Sell through additional retail outlets
- Introduce a new, improved version of the old product
- Use a new advertising campaign

### 3.7. Pricing

- It is important to select an appropriate price to complement a brand image; a value for money brand should have a low price.
- The business must constantly monitor what its competitors are charging for their products to make sure its prices remain constant.
- A business can adopt new pricing strategies for:
  - To break into a new market
  - To increase market share
  - To increase profits
  - To make sure all costs are covered and a particular profit is earned

#### Pricing methods

- There are 5 main types of pricing methods:
  - Cost-plus pricing:
    - It involves estimating how many of the product will be produced, then calculating the total cost of producing this output and adding a percentage mark – up for profit.
    - The method is easy to apply.
    - You could lose sales if the selling price is a lot higher than your competitors' price.
    - Total cost /output+ % mark up.
  - Competitive pricing:
    - High sales as prices are at a realistic level
    - To decide prices, research needs to be done, it costs time and money
  - Penetration pricing
    - It is when the price is set lower than the competitors' prices in order to enter a new market
    - It ensures sales are made
    - It ensures the new product enters the market
    - Low profits
  - Price skimming
    - It is when a high price is set for a new product on the market
    - Established a brand image
    - Established the product of good quality
    - Costs of R&D maybe covered
    - It may pull off some potential customers due to high prices
  - Promotional pricing
    - It is when a product is sold at a very low price for a short period of time
    - Help get rid of unwanted stock
    - May raise sale, if they were falling
    - Low profits, low sales revenue
  - Psychological pricing

- It is when price is set to match consumer expectations and perceptions of a product
- It may involve charging high prices for high quality goods
- It may involve charging the price below a whole number
- Low prices for basic necessities may give a good impression of being good value of money
- Ensures sales are made
- Sales revenue may be lost
- Competitors may follow, low effect
- Dynamic pricing
  - It means charging different customer groups, different prices for the same product because they have different demand levels
  - Made it easier to adopt with the growth of online marketing
  - High revenue and profits
  - Increased costs

#### Price elasticity of demand

- Price Elasticity – It is a measure of responsiveness of demand to a change in price
- PED is affected to the no of substitutes available
- Price-Elastic Demand is when the % change in demand is GREATER than the % change in price i.e., prices increase by 5% but then sales decrease by 10%. Therefore, there is falling revenue for the business
- Price-Inelastic Demand is when the % change in demand is LESS than the % change in price
- This means you can increase the price of the product a lot without the demand changing (i.e., oil & petrol because people have to buy it)

### 3.8. Place – Distribution Channels

- Product should be available when and where customers need them
- Wrong place, low sales and profits
- Place must be convenient for consumers

There are 4 main distribution channels:

- **Manufacturer sells products directly to consumer** (i.e. car components to car factory)



Advantages	Disadvantages
Very simple	Impractical because consumers don't usually live near factories
Suitable for products that are sold straight out of factories	Not good for products that can't be sent easily by post (may be expensive to ship it)
There is a lower price for consumer (cuts retailer)	Not cost effective

Advantages	Disadvantages
Direct contact with customers	

- Producer **sells to retailers which sell to consumers:** (i.e. farms selling food to big supermarkets)



Advantages	Disadvantages
Manufacturer sells lots of stock to retailer	There is no direct contact with customers which makes it hard to create customer loyalty
Cheaper transportation costs because all products go to one place	
Lower storage costs for the manufacturer	

- **Producers sell to wholesalers** – which buy in bulk and then divide their stock into smaller quantities and sell them to retailers



Advantages	Disadvantages
Reduces storage costs for small retailers because small quantities are sold	More expensive to buy from wholesaler than from manufacturer
Small quantities so transport costs are low	Wholesaler might not have all the products a retailer wants
Wholesaler can give feedback on what sells well to producer	Takes longer to get to consumer
	Huge gap between manufacturer and customer
	May stock competing products

- A manufacturer hires an agent (person or business) that will sell products on behalf of manufacturer



Advantages	Disadvantages
Agents know the most profitable places & prices to sell in other markets that manufacturers may not know	Manufacturer loses lots of control on the way the product is sold to customers
Agents will provide advice on best ways to survive new markets	Higher costs for consumers

**E-commerce**

- Selling of goods and services through the internet
- Benefits to the business:
  - Cheaper
  - Customers encouraged to buy in bulk
  - Business-2-Business e-commerce is cheaper
  - Wider options for customers, brand image and loyalty
- Problems to business:
  - Website must be maintained
  - High distribution costs
  - No direct contact
  - Returns – higher costs
  - Stock system will be needed
- Benefits to consumers:
  - No need to go out
  - Wide options
  - Easy comparison
  - Payment through net banking
  - Easy access to imported goods
  - Low prices
- Problems to consumers:
  - Internet needed
  - High chances of fraud and theft
  - Products can't be physically examined
  - No direct contact

**Selecting which distribution channel to use**

- Type of product
- Is it technical?
- How often is it purchased?
- How expensive is it?
- How perishable is it?
- Where are customers located
- Where do competitors sell

**3.9. Promotion**

- Promotion gives info about the 4P's
- Essential when trying to increase/ create brand loyalty
- Promotion includes:
  - Advertisements –
    - Above the line
    - TV, newspaper, internet
  - Sales promotion
    - Below the line
    - Free gifts, coupons, samples
    - Used for short periods

**Aims of promotion**

- To raise awareness about a firm's products
- Encourage customers to make a purchase
- Increase sales
- Inform people about particular issues, used by the govt
- Introduce new products in the market
- Create brand image
- Improve company's image
- Compete with competitors

## Advertising

- There are 2 types of advertisements:
  - Informative Advertisement – where the promotion of a product focuses on giving information about a product (i.e. the benefits of the product)
  - Persuasive Advertisement – where the promotion of a product focuses on persuading the consumer that they really need the product and they should buy it
    - The advertising process:
      - Set objectives
      - Decide the advertising budget
      - Create an advertising campaign
      - Select the media to use
      - Evaluate the effectiveness of the campaign

## Types of advertising media

- Television –
  - Reaches millions of people
  - Can be shown attractively
  - Can be targeted at a specific audience
  - Very expensive
  - No written record
  - Works for food, clothing, technology
- Radio –
  - Cheaper than TV
  - Reaches to many people
  - Can use songs
  - No visual support
  - Expensive
  - No written record
  - Maybe unclear
  - Not a wide target audience
  - Works for local services, events
- Newspaper –
  - Cost effective
  - Hard copy available
  - Detailed info can be provided
  - Reaches out to millions
  - Can be targeted at specific audience
  - May not be attractive
  - Works for banks, cars, etc.
- Magazines –
  - Attractive
  - High quality
  - Can be targeted at a specific audience
  - Expensive
  - Published monthly/ weekly
  - Works for expensive perfumes, medical equipment
- Posters –
  - Permanent
  - Cheap
  - Attractive
  - Seen by everyone
  - Prone to vandalism
  - No detailed info
  - Can be missed

- Works for local events, daily necessities
- Cinemas, DVDs –
  - Visual image
  - Cheap
  - Effective
  - Limited audience
- Leaflets –
  - Cheap
  - Wide audience
  - Permanent
  - May not be read and missed
  - Works for local events
- Internet –
  - High info
  - Instant orders
  - Direct mail is cheap
  - May not highlight the website
  - Limited internet access
  - High competition
  - Security issues
  - Works for clothes, books
- Product placement –
  - Associated with image
  - Specific target audience
  - Expensive
  - May have negative effects
  - Works for expensive products

## Sales Promotion

- Sales Promotions – when incentives (i.e. special offers/sales) are used to increase sales (short term)

## Types of sales promotion

- Price reductions –
  - Includes coupons
  - Linked to loyalty cards
  - Encourages consumers to try products and become customers
- Gifts –
  - Small gifts to encourage purchases
  - Main aim to get customers to buy at regular intervals
- BOGOF –
  - Multiple purchases are encouraged
- Competitions –
  - Packaging can allow customers to enter competitions
  - Encourages sales
  - Expensive prices •
- Point of sale display –
  - Place where the product is sold
  - Special display
- After sales services –
  - For expensive products, good after services encourages consumers to buy their product
- Free samples –
  - Can be handed out to shops to encourage sales
  - Maybe delivered at home

### Advantages of sales promotion

- Can promote sales in losses
- Encourages new customers
- Encourages customers to buy greater quantities
- Try new products
- Choose your brand over competitors

### Marketing Budget

- Marketing budget is the financial plan for marketing product/brand for a period of time
- When deciding which type of promotion to use, marketing budget is an important factor
- Choose the most cost-effective method
- This is where small business struggle compared to big businesses, because their budget is so much smaller.

### Factors influencing type of promotion

- Stage of PLC
- Nature of product
- Cultural issues involved in international marketing
- Media used must depend on:
  - Literacy rate
  - Poverty rate
  - Availability of radio and cinema
  - Nature of target market

## 3.10. Promotion

### Public relations and sponsorship

- It is concerned with promoting a good image of the brand
- Ways to increase public awareness:
  - Sponsor events linked with good causes
  - Donate in charities

### Technology & Marketing mix

- New technology gives greater opportunities to market goods
- The 4 P's might change
- Internet allows businesses to understand customer habits

### Social media and website

- Advertising through social media:
  - Target specific demographic group
  - Guarantee it reaches customers
  - Cheap
  - Reach people of all ages
  - Quick responses to market changes
  - Have to pay for pop ups
  - If advertising is annoying, reduce sales
  - Lose control
  - Maybe altered, reducing business reputation

- Advertising on own website
  - No extra costs
  - Control adv
  - Change info quickly
  - Attractive
  - High info
  - High costs
  - May not be located
  - High competition

## 3.11. Marketing Strategy

- It is a plan to combine the right combination of the 4 elements of the marketing mix for a product or service to achieve a particular marketing objective
- Marketing strategy developed depends on:
  - Size of market
  - Number and size of competitors
  - Marketing objectives
  - Target market
  - Finance available
- Marketing objectives may include:
  - Increasing sales
  - Improve the existing product
  - Increasing sales of a new product
  - Maintaining/ increasing market share
  - Increasing sales in a niche market • Increase market share/maintain market share
- For example: A product is made, priced reasonably, and meets the consumer needs, but there is no promotional element. No one will buy it because people don't know about its existence
- Or if a product is made that doesn't meet consumer needs, so it won't sell regardless of the price set
- It is crucial to have all elements working together in order to influence consumer decisions (buying the product)

## 3.12. Legal Controls in Marketing

- There are many laws in different countries to protect consumers from businesses taking advantage of their lack of knowledge or lack product information
- These legal controls include (in the U.K.):
  - Weights and measures
    - Selling underweight items or using inaccurate equipment's to weigh goods is illegal
  - Sale of goods
    - Supplying goods of bad quality/ in an unsatisfactory condition is illegal
  - Supply of goods and services act.
    - Producing and selling goods in an unhygienic place is illegal
  - Distance selling regulations
    - A consumer should have a minimum of 7 days cooling period (a consumer should have 7 days to change their mind about purchase they made)
  - Trade descriptions

- Supplying a good/ service which is unsafe/ not fit for the purpose is illegal
- Giving false info or misleading claims is illegal
- Misleading consumers about the true price is illegal
- Making false claims about special deals and offers is illegal
- Offensive or indecent ads are illegal
- Complying with all legal controls can raise total costs of a business by:
  - Goods/ services may have to be redesigned to ensure quality and safety
  - Ads may have to be altered
  - Some promotion techniques may have to be changed
  - May have to change packaging
  - Prices may have to be controlled and altered
  - Increase employment

### 3.13. Entering New Markets Abroad

- The globalization of businesses has been increasing over the years, there are opportunities & problems to this:

Opportunities	Problems
Growth potential in other countries: countries are developing and population incomes are increasing	Lack of knowledge of competitors or consumer habits
Markets in original country might be saturated (sales are low)	Cultural differences: for example, alcohol won't sell well in middle east
Can produce products in abroad and learn about its market to increase sales	Exchange rates: in some countries their currency isn't stable so price of importing goods increase
Trade barriers are lowered in most countries so it is cheaper to enter markets	Transport costs are more expensive

- However, there are many methods to reduce and overcome the problems of entering a new market:

Problem	Method to overcome
Lack of knowledge (& Cultural Differences)	Joint-Ventures: by working together/merging with local businesses in the same market, a business will gain a lot of important knowledge about the culture & market \n Franchising: letting people from the market abroad which have local knowledge to choose location of shop

Problem	Method to overcome
Transport costs are expensive	Licensing: the business gives permission for a local business to sell goods under its name, so they do not have to physically import all the products
Cultural Differences	Localizing Existing Brands: where a business still has the same brand image but adapts it to the market it is in (i.e. McDonalds cooking vegetarian meals in India)

## 4. Operations management

### 4.1. Production of Goods and Services

- Production – the making of a product or service to satisfy consumer wants and needs
- It involves adding value to a business's products
- A business combines the inputs/economic resources/factors of production to produce a more valuable output (this could be a good or a service)
- The 'inputs' include:
  - Land – For factories or for materials
  - Labour – Employees
  - Capital – Money/finance
  - Enterprise – Managers
- Businesses want to combine all of these inputs efficiently to keep costs low to increase profits
- For a business to be competitive, it must combine its resources effectively, reduce disposal costs, total costs and raise profits
- Labour-Intensive Production – where lots of workers are used rather than machines to make goods. Usually done in countries with low wages so that it is more efficient.
- Capital-Intensive Production – where businesses use machines/robots rather than workers. Usually done in developed countries where the wages are high.

#### Operations department

- Operations department's role is to take inputs and change them into outputs for consumers
- Operations manager is responsible for making sure raw materials are available and are made into finished goods
- Most manufacturing businesses have
  - Factory manager- responsible for quality and quantity of products
  - Purchasing manager – responsible for providing the required materials and equipment
  - Research and development manager – responsible for design and training of new products

#### Productivity



- Productivity – It is a way of measuring a business's efficiency
- Productivity = quantity of output/ quantity of input
- Businesses often want to measure the productivity of labor
- Labour productivity = output / no. of employees
- Increased productivity leads to lower inputs used to produce the same level of output or same number of inputs used to create greater number of goods
- As employees become productive, per employee output rises, costs of production falls
- Many ways to increase productivity:
  - Improve factory layout to reduce time waste and raise efficiency
  - Introduce automation
  - Improve labor skills by training
  - Improve quality control
  - Improve employee motivation
  - Improve inventory control
- Benefits of increasing efficiency:
  - More output compared to inputs
  - Lower costs per unit (AKA Average cost)
  - If there is more output, maybe less workers needed, less people to pay wages
  - If there are less people working, raising their wages will increase motivation and so productivity

### Inventory

- Why do businesses hold inventory?
  - To ensure enough inventory is available to satisfy demand, inventory levels must be controlled
- Inventory includes:
  - Raw materials
  - Work in progress
  - Finished goods
- When inventory reaches a certain point, they must be reordered to bring the inventory to max level. Inventory must be reordered before it gets too low
- If inventory levels are high, costs of production will be high and opportunity costs will also be high

### Lean production

- Variety of techniques to cut down wastes and raise efficiency
- It tries to reduce production time
- Types of wastes:
  - Transportation - when the goods are being moved unnecessarily → fuel price, may get damaged
  - Overproduction - leads to high storage costs and possible damage to goods while in storage.
  - Over processing - when sophisticated machines are being used to do simple tasks
  - Waiting
  - Motion - any action made by an employee that does not relate with the production of goods wastes time
  - Unnecessary inventory

- Defects - when goods have faults/defects that require them being inspected/fixes wastes time
- Advantages of lean production
  - Less storage costs
  - Quick production
  - Better use of equipment
  - Less money tied up in inventory
  - No returns
  - Greater health and safety
  - Cut some processes that aren't important
  - Low costs lead to low prices due to higher competition and high profits

## 4.2. Lean Production

### Types of Lean Production

- Kaizen
- Just-in-time inventory (JIT)
- Cell production

### Kaizen

- Kaizen means continuous improvement in Japanese
- Its main focus is to eliminate waste
- The ideas are got by holding frequent meetings with workers where they discuss about problems and their solutions
- Advantages –
  - High productivity
  - Less space needed for production
  - Work in progress is low
  - Improved layout of factory may lead to combine jobs. This will reduce labor demand

### Just in Time

- It involves eliminating the need to hold inventories
- Supplies arrive just at time they are needed
- Low storage costs
- Quick sales
- Quick money received
- To operate in JIT, businesses need to have reliable suppliers and an efficient ordering system

### Cell Production

- This is where the production process is divided into separate units, each making an identifiable part of the good
- High motivation
- Less chance of strike
- High efficiency
- High boredom

## 4.3. Methods of Production

- 3 main methods of production:

- **Job Production** – products made one at a time
- **Batch Production** – a quantity (batch) of a product is made, then a batch of another product is made
- **Flow Production** (mass) – large quantity of products made in a continuous process
- **Job Production:**

Features	Benefits	Limitations
Products are made specifically to order	Good for 'one-off' products	Often labor intensive, expensive
Each order is different	Meets exact requirements of customer	Production takes longer
Eg. bridges, ships, cakes, cinema, films, suits	Varied work, increases employee motivation	Any errors made are expensive to fix
	Ability to charge higher prices	Materials are more expensive
		No possibility of purchasing economies of scale

- **Batch Production:**

Features	Benefits	Limitations
Similar products are made in batches	Flexible work, can change products easily	Machines must be reset to do different batches
Ex. bakery: makes one type of bread, then one type cake, furniture, clothing	Gives some variety to worker's jobs	Semi-finished products may need to be transported around (+ cost)
	More variety, more consumer choice	Need space for stocks of raw material (high storage costs)
		High work in progress inventory
		Expensive and time taking

- **Flow Production:**

Features	Benefits	Limitations
Large quantities of a product are produced	High output, capital intensive more efficient	Very boring for employees
Ingredients start at one end & flow to the other end, ready to be sold	Costs are low	High cost of inventory of output & raw materials

Features	Benefits	Limitations
Cars, drinks, electronics, any mass-made products are made this way	Works 24/7, no need for labor	If machine breaks down, whole production stops
	No need for moving goods around (all made in the same place)	

- Factors influencing which production method to choose
  - Nature of product
  - Size of market
  - Nature of demand
- Technological changes
  - Automation – when equipment in factory is controlled by a computer to do mechanical processes (i.e., painting car). Only workers are to ensure it runs smoothly
  - Mechanization – when production is done by machines but operated by people. Used to do difficult, precise or dangerous tasks. Work 24/7, quicker and more accurate.
  - Computer Aided Design (CAD) – software that helps design or re-style products quickly, allows technical sketches to be very detailed
  - Computer Aided Manufacture (CAM) – when computers monitor production and control machines/robots
  - Computer Integrated Manufacturing (CIM) – when software that designs the products is integrated with the machines that produce (CAM + CAD)
  - Using technology keeps business ahead of competition, costs falling, prices falling and quality rising

## Electronic payments methods

- EPOS (electronic point of sale) – it is used at checkouts where barcodes are scanned and displayed on the receipt. The inventory is automatically changed and reordered when the reorder level is reached
- EFTPOS (electronic funds transfer point of sale) – it is where an electronic cash register is connected to the retailer's bank accounts and the money is directly transferred when the shopper's bank info is entered

## New technology

- Advantages of new technology
  - High productivity
  - Higher training given
  - Motivation rises as the quality of work increases
  - Higher job satisfaction
  - Better quality products
  - Customer demand will be, high sales

- High customer satisfaction
- Brand loyalty
- Quick communication
- Low costs, high profits
- Disadvantages of new technology
  - High unemployment
  - Expensive
  - High risks
  - Low motivation
  - Replacement and maintenance costs are high

## 4.4. Costs and Scale of Production

### Need to measure costs

- So that it is compared with revenue and can be used to calculate profit/ loss
- To decide the price
- Costs of buying raw materials, land can be compared
- Accurate cost info is very important to managers for future planning and decision making

### Business Costs

- Fixed (overhead) Costs (FC) -
  - Costs which do not change with output in the short run.
  - Also known as overheads or indirect costs
  - Fixed Cost = Total cost - Variable cost
  - Examples of Fixed Costs:
    - Rent of factory: even if you produce lots of products, the rent price will be the same
    - Insurance: you set the insurance cost before-hand
    - Bank fees: bank fees are a set price; they don't change depending on the products produced
    - Management Salaries: they are set regardless of production
    - Staff cost (Security)
- Variable Costs (VC) -
  - Costs which vary directly with output
  - Also known as direct costs
  - Variable cost = Total cost - Fixed cost
  - Examples of Variable Cost:
    - Raw materials: the more you produce, the more materials you need
    - Electricity & Gas: Energy is paid by use. if you are producing more, more electricity is being used
    - Shipping cost: Making more products means you have to ship more items and shipping is paid by weight
    - Total Cost - Fixed and variable costs combined
    - Average Cost (Per Unit) - total cost of production divided by the total output. Referred to as Unit Cost

## 4.5. Economies of Scale (EOS)

- As scale of production rises, LRAC fall
- They are factors that lead to a reduction in average costs as a business's size increases
- Types of economies of scale:
  - Purchasing economies -
    - When a business buys in bulk, it tends to receive discounts decreasing the price of each good
  - Marketing / selling economies -
    - When the company advertises for goods it will pay the same amount to advertise a greater number. Therefore, when marketing for a higher output, unit costs fall decreasing ATC
  - Financial economies -
    - Banks tend to lend to larger companies with low rates of interest as they borrow high amounts and their collateral value is high
  - Managerial economies -
    - Large firms have opportunities to employ specialists who will help reduce wastage, increase efficiency and productivity
  - Technical economies -
    - Large firms can use latest technologies which are efficient

## 4.6. Diseconomies of Scale (DEOS)

- As scale of production rises, LRAC rise
- They are factors that lead to an increase in average costs as a business grows beyond a certain size
- Types of diseconomies of scale:
  - Poor communication
  - Low morale -
    - Large businesses have many employees and are not everyone is connected to the top management, reducing their motivation levels
  - Slow decision making -
    - Large businesses have longer chains of command due to which info and instructions take long to reach the desired person, slowing communication, slow decision making

## 4.7. Break-Even Charts

- Break even charts show how costs and revenues of a business change with sales. They show the level of sales the business must make in order to break even
- Breakeven level of output indicates the minimum amount of goods a business must produce in order to earn a profit
- The break-even point is where:  
**Total Cost = Sales Revenue**  
**Where the revenue line intersects the total cost**
- Breakeven point (BEP) = no profit, no loss
- BEP = Total fixed cost / CONTRIBUTION PER UNIT
- Contribution per unit = Selling price per unit \* variable cost per unit

- Sales revenue is the income of a business from sales of goods or services in a period of time.
- To draw a break-even chart, you must include:
  - Fixed Costs line
  - Variable Costs line
  - Total Costs line
  - Sales Revenue line
- Anything before the break-even (BE) point is loss
- Anything after the break-even (BE) point is profit
- 'y' axis measures money amounts (cost & revenue)
- 'x' axis shows the number of units produced or sold

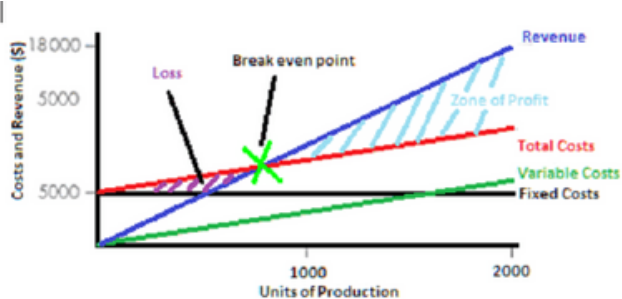

- Total cost is variable cost line starting from fixed cost
- If the total cost increases, then the BE point increases and total cost's line becomes steeper
- If revenue increases, then revenue line becomes steeper and so the break-even point decreases
- **Benefits of break-even charts:**
  - Managers can read of the graph if the company **expects profit or loss**, and can see how much profit/loss the will have at any level of output
  - They can **attempt different scenarios** and see the impact it will have on the profit or loss of the business. It lets managers **try out different possibilities** to find out which one is the best. (i.e. increasing the selling price, increasing production)
  - It can be used to show the **SAFETY MARGIN** – the **amount by which sales exceed the break-even point**. For example: if a business' break-even point is at 400 units and they're producing 600 units, their safety margin is  $600 - 400 = 200$ .
- **Limitations of break-even charts:**
  - Break-even charts **assume that all products made will be sold**. It does not show the possibility that inventories may build up if they are not sold
  - Fixed costs only stay the same **if the scale of production stays the same** (doubling the output will also increase the fixed cost because they must need bigger factory, more machinery, labour, etc)
  - Break even charts **assume that costs and revenues can be drawn with straight lines**, which doesn't happen in real life.
  - It assumes costs and revenue increase at a constant rate

## 4.8. Achieving Quality Production

- **Quality** – to produce a good or a service which meets customer expectations
- **Quality is important for businesses because:**

- It establishes the brand image
- It builds brand loyalty
- It maintains a good reputation
- It will help to increase sales
- Attracts more and new customers
- **If quality is not maintained, businesses will:**
  - Lose customers to other brands/competitors
  - Have to replace faulty products or repeat poor service which raises costs for business
  - Have a bad reputation because people who had bad experiences will tell other people, etc. Leads to lower sales & revenue

## Quality Control

- **Quality Control** – Checking for quality **at the end** of the production process, whether it is a product or a service.
- Quality control is a traditional way to make sure that products leave the factories with no defects
- The jobs of people in quality control departments are to take samples at **regular intervals** to check for errors.
- If errors are found, the whole batch of production might have to be redone.
- Their job is also to prevent any production errors before they happen during production, which will lead to money loss
- Sometimes, businesses bring a mystery customer to test out the **service** to check if the quality is as expected
- **Advantages of Quality Control:**
  - Eliminates faults/errors before the customer receives product or service
  - Less training is required for the workers
- **Drawbacks of Quality Control:**
  - Expensive, as employees need to be paid to check the product or service
  - Identifies the fault but not how and why it occurred so it is difficult to remove the problem
  - Increased costs if products have to be scrapped or reworked or service repeated

## Quality Assurance

- **Quality Assurance** – checking for the quality standards **throughout** the production process
- It will make sure quality standards are set and then it will apply these quality standards throughout the business
- **Advantages of Quality Assurance:**
  - Eliminates faults/errors before the customer receives product or service
  - Fewer customer complaints
  - Reduced costs if products don't have to be scrapped or reworked or service repeated
- **Drawbacks of Quality Assurance:**
  - Expensive to train employees to check products
  - Relies on employees following instructions of the standards set by company

## Total Quality Management (TQM)

- **Total Quality Management (TQM)** – the **continuous improvement** of products and processes by focusing on quality at **each stage** of production
- Many companies use Total quality management.
- It tries to **“get it right the first time”** and have no defects
- It focuses on ensuring 100% that the **customer is always satisfied**. Customer is **not just the final user**, it also includes other people and departments within the business
- This means that quality needs to be maintained throughout the business and no faults should occur.
- **Advantages of total quality management:**
  - Quality is built into each part of the production. It becomes a habit for the employees
  - Eliminates virtually all faults/errors before the customers receives.
  - No customer complaints so the brand image is improved
  - Waste is removed and efficiency increases which means less money is wasted (higher profits)
- **Drawbacks of total quality management**
  - very expensive to train employees to check the product or service at every stage of production
  - Relies on employees following the ideology of TQM

## 4.9. Location Decisions

- Businesses look up for locations when:
  - New business
  - Present location is unsatisfactory
  - Change in business aims and objectives
  - Expansion
- **Factors that influence the *choice* of location of a MANUFACTURING business:**
  - Production methods and location decisions
    - Production methods play a significant role in deciding the location of a business.
    - Job production – the business will be small and won't have much effect on competitors there. Location of suppliers won't have affect much on the business. Ex. A bakery
    - If there is a large-scale production, then competitors in that area will be highly affected and the business will prefer closer suppliers as raw materials will be in a huge amount and transportation costs maybe high if supplier is too far.
  - Market
    - When a product is heavier than its raw materials, then businesses decide to locate its factory near the markets rather than the supplier as a business will find it much cheaper to do so.
    - Due to advances in transportation facilities the distances between factories and markets of heavy products doesn't play a vital role.
      - Perishable products need to be delivered quickly.
  - Raw materials/ components
    - If goods and raw materials are very heavy then transportation costs will be high. Then a company may want its factory to be located near the supplier.
- External economies of scale
  - When two firms support each other or work together, they will be able to respond quickly to any important decisions to be made or any breakdowns.
- Availability of labour
  - Every manufacturing business requires labour.
  - If a business requires only skilled labour then it will try and locate near a place where people with various skills live.
  - If a business requires unskilled labour then it will be located in a place when wage rates are low and unemployment is high.
- Government influence
  - When a government wants to encourage businesses to locate in a particular area, it will offer state – funded grants, to encourage firms to move there
  - High unemployed area, it may provide grants to businesses to locate there
- Transport and communication
  - Businesses need to be closer to transport systems
  - Exported products, ability to reduce transport costs
  - Reduces time taken
- Power and water supply
  - Availability of power is very important
  - Some businesses need to have reliable power sources to continue production
  - Some production processes require a reliable water source
- Climate
- Factors that influence the choice of location of a SERVICE SECTOR business:
  - Customers
    - Services which require direct contact, must be located near the customers
    - Services where personal contact isn't required, location doesn't affect
  - Technology
    - Technology has allowed e commerce so location doesn't play a vital role
  - Personal preference of owners • Owners often decide the business's location
  - Availability of labour
    - If a business is labour intensive it must locate in areas where labour is easily found like towns and cities
  - Climate
  - Near to other businesses
    - Some service/ businesses serve large companies and so should be able to reach them immediately, therefore they must locate closer to them
  - Rent/ taxes



- If services don't require personal contact, they can locate in places with lower rents and tax rates
- Factors that influence the choice of location of a RETAILING business:
  - Shoppers
    - Retailers want popular areas as they attract customers
    - It depends on the type of product
    - Expensive – place where high income people live or visit regularly
  - Nearby shops
    - Being located near a shop which is frequently visited means people may shop in between while visiting other shops
    - A place with high competition attracts more customers as they have greater choice
  - Customer parking availability/ nearby
    - Convenient and nearby parking lots will encourage people to visit your shop
  - Availability of suitable vacant premises
    - If proper location isn't available, a company can't locate there
  - Access of delivery vehicle
    - Businesses try to find places near transport businesses to gain easy access to delivery vehicles
  - Rent/ taxes
    - Popular area, high demand, high rent
    - Less popular, low demand, low rent
  - Security
    - A place prone to theft may reduce a business's chances to locate there
    - Insurance companies may not insure such companies
  - Legislation
    - Some countries may have laws restricting trade in some parts
- Factors influencing decision of which country to locate operations in:
  - New market overseas - when a business sees an increase in sales overseas, it may decide to move/relocate there, instead of transporting products there
  - Cheaper Source of material – if the raw material runs out, the business must either bring in alternative supplies from somewhere else or relocate to new country with these raw materials, it also might be cheaper than transporting it
  - Difficulties with the labour force and wage costs – if business is located in country where wages keep rising, business may decide it is more profitable to relocate to country where wages are lower
  - Rents/taxes considerations – if other costs such as rent or taxes increase, this might cause business to relocate to countries where it is lower
  - Availability of government grants and other incentives - If governments want to increase foreign investment and job opportunities, then they will provide grants,

subsidies, lower taxes. They may do this to provide new skills and increase employment

- Trade and tariff barriers – If trade barriers are high, the business's chance of locating there would reduce costs

## 5. Financial information and decisions

### 5.1. What does a finance department do?

- Record financial transactions
- Prepare final accounts
- Cash flow forecast
- Make important decisions
- Provide info to managers

### 5.2. Why does a business need finance?

- Finance is money which is needed to meet the day – to – day expenses of a business. This is known as capital.
- Capital is needed for:
  - Starting up a business
    - Capital which is needed to buy the factors of production and inventories so that a firm can begin training. It is known as startup capital.
  - Expansion
    - The amt needed to expand a firm. It can be done by: additional assets, takeover/ merger, new products, new markets.
  - Increase working capital
    - It is known as the life blood of the business.
    - It is divided into:
      - Capital expenditure: money spent on non – current assets.
      - Revenue expenditure: money spent on day to day, recurring expenses.
- There are 2 types of finance needs:
  - Short-Term Finance Needs: Finance needs to pay things that last less than a year, (working capital) - includes wages, rent
  - Long-term Finance Needs: long term investments (that last more than 1 year). Money to buy Fixed Assets (i.e., buildings)

### 5.3. Sources of Finance

- The main sources of capital include:
  - **Internal Sources** – Obtained by business itself
  - **External Sources** – Obtained from outside business

#### Internal sources of finance

- Retained profits –

- Profit left in the business after shares are distributed. Also known as ploughed back profits.
- Doesn't have to be repaid
- Doesn't incur interest
- New business can't use it
- Small firms won't be able to gain enough money
- Reduces owners' payments
- Sale of existing assets –
  - Assets not needed can be sold to earn money.
  - Better use of unwanted capital
  - Doesn't increase debts of a business
  - Takes time
  - Not available for new firms
  - Could have been used during expansion
- Sale of inventories –
  - Reduces opportunity cost
  - Reduces storage costs
  - May disappoint customers if sudden change in demand is not met
- Owner's savings –
  - Quick availability
  - No interest is paid
  - Savings may be low
  - Increases risks of owners

## External sources of finance

- Issue of shares –
  - Permanent source of capital
  - Doesn't need to be paid back
  - No interest
  - Shareholders expect dividends
  - Ownership of the company may get shared
- Bank loans –
  - A sum of money obtained from a bank which must be repaid with interest
  - Quick, easy to arrange
  - Available for varying length of time
  - Large companies receive low interest rates if large sums are taken
  - Must be repaid with interest
  - Collateral security must be given
- Selling debentures –
  - Debentures a certificate that is issued to a debenture holder for the money they lent which has to be repaid within a span of 20 – 25 years.
  - Long term finance
  - High interest
- Factoring of debts –
  - Debt factors are specialist agencies that buy the claims on debtors of firms for immediate cash.
  - Availability of immediate cash
  - The risk of collecting the debtors becomes the factors not the business's
  - Firm doesn't receive 100% amount
- Grants and subsidies –
  - Don't have to be repaid
  - Given with strings attached

- Micro finance –
  - Mostly banks don't give loans to poor people
  - Special institutions have been set up which lend poor people
  - High interest rates
  - Greater risk for the lender

## Short term VS long term sources

### Short term

- Overdrafts –
  - The bank gives the business the right to overdraw their bank account
  - Flexible form of borrowing – varies each month
  - High interest
  - Cheaper than loans in short run
  - Variable interest rates
  - Bank may ask the repayment with a short notice
- Trade credit –
  - It is when businesses delay the payments to suppliers
  - Interest free loan
  - Reduces cash outflows in the short run
  - May not provide discounts
  - Factoring of debts

### Long term

- Bank loans –
  - They are payable over a fixed time period
- Hire purchase –
  - It allows a business to buy a fixed asset over a long period of time with monthly payments which include interest
  - Doesn't have to find a large cash sum to purchase the asset
  - Cash deposit is paid at the start of the month
  - High interest rates
- Leasing –
  - It allows a firm to use an asset but doesn't have to purchase it
  - Doesn't have to find a large cash sum to purchase the asset
  - Maintenance is taken care by leasing company
  - High costs
- Issue of shares –
  - Only available to limited companies
- Long term loans or debt finance
- Debentures

## Factors when choosing source of finance

- The main factors considered in making financial choice:
  - Size of business & Legal Form (type of business): Public limited companies have larger choice of sources of finance because they pay less interest (less risk)
  - Amount of capital required: if you need just a little money you won't issue new shares

- Purpose of capital & time period: The general rule is that the finance source should match the finance need:
- If use of capital is long-term, source should be long-term (same with short term)
- Existing Loans (risk and gearing ratio): if a business already took out lots of loans, banks will think it is too risky to finance

## 5.4. Cash-Flow Forecasting & Working Capital

- Cash is a **Liquid Asset** – it can be immediately available to spend on goods & services
- **Cash Flow** – the cash **inflows** (money received by business) & **outflows** (money paid) over a period of time
- Cash inflow – money coming in the business
  - Sale of goods
  - Sale of assets
  - Payments to debtors
  - Borrowing money
  - Investors
- Cash outflow – money going out of the business
  - Purchase of goods
  - Purchase of noncurrent assets
  - Payments of salaries
  - Repaying loans
  - Trade payables

### Cash flow cycle

- It shows the stages between paying out cash and receiving cash
- Stages:
  - Cash needed to pay for
    - Materials, wages
    - Goods produced
    - Goods sold
    - Cash received
- Larger it takes for the cash flow cycle to be completed the greater should be the working capital
- Cash flow is not the same as profit
- Profit consists of goods sold on credit whereas cash flow is the amount of cash sales a business made in a month.
- When profitable businesses run out of cash it is known as insolvency.
- Due to:
  - Overtrading
  - Long credit time
  - Less credit time received
  - Many fixed assets purchased

### Cash flow forecast

- **Cash-Flow Forecast** – an estimate of future cash inflows and outflows.
- A cash-flow forecast shows the expected cash balance at the end of each month:

- Cash flow forecasts are just little charts with values comparing 2 different time periods (months/years etc.)
- **Net Cash Flow** – The difference between the cash inflow and outflow (**inflow – outflow**)

	January	February	March
OPENING BANK BALANCE (A)	10,000	15,000	(15,000)
Cash inflows (B)	35,000	45,000	50,000
Cash outflows (C)	30,000	65,000	40,000
NET CASH FLOW (D) (= B – C)	5,000	(20,000)	10,000
CLOSING BANK BALANCE (= A + D)	15,000	(5,000)	5,000

### Uses of cash flow forecast

- Cash flow forecasts are useful because:
  - Starting up a business
    - The first few months are very crucial to every business as owners don't realise the amount of cash needed due to which they fail
    - Businesses need to spend to labour, land, and capital. They even have to advertise and promote extensively
    - Many owners don't understand the importance of cash flow in a business due to which they fail.
  - Keeping the bank manager informed
    - A cash flow forecast will help a business receive a loan
    - The bank manager needs to be aware when the amt is needed, for how long, when it will be repaid
  - Managing an existing business
    - A cash flow forecast will help a business receive a loan
    - The bank manager needs to be aware when the amt is needed, for how long, when it will be repaid
  - Managing cash flow
    - Businesses with high bank balance can use their cash effectively in other areas

### How to overcome cash flow problems?

#### Short term solutions

- Increasing bank loans will inject more cash into the business but both interest and loan will have to be paid
- Delaying payments to suppliers will decrease cash outflows in the short run but supplier may refuse to provide discounts or supply
- Reducing credit period may help a business increase short term cash inflows but customers may switch to competitors
- Delaying purchase of fixed assets will reduce cash outflows but in the long run a company may lack efficiency as they don't have up – to date technology

#### Long term solutions

- Attracting new investors
- Cutting costs and increasing efficiency using lean production
- Develop new products

## 5.5. Working Capital

- It is the capital available to a business in the short run to pay for day – to – day expenses

**Working Capital = Current Assets – Current Liabilities**

- It is the life blood of the business
- It assists in identifying the credit reputation of a business
- Working capital can be in the form of:
  - Cash
  - Value of debtors
  - Value of inventory
- Overall success depends on the working capital position
- Working capital should be handled properly because it shows investors & banks how efficient a business is and its financial strength

## 5.6. Income Statements

- Accounts are the financial records of a firm’s transactions
- Accountants are professionally qualifying people who have responsibility of keeping accurate accounts and producing final accounts
- Final accounts are produced at the end of financial year and give details about the profit/ loss made over the year and the worth of the business
- Profit is the money left over after total costs have been subtracted from the sales revenue.
- The simple equation for profit:  
Profit = Sales revenue – total costs
- Profit can be made by:
  - Increasing the sales revenue, so that it is higher than the production costs
  - Reducing the production costs

### Importance of profits

- Profit is very important, especially for the private sector companies (not owned by government)
- Reward for enterprise
  - Entrepreneurs have special qualities and they must earn reward for that
- Reward for risk taking
  - Shareholders and investors take risks when they provide capital, profits act as a reward for those risks
  - Payments act as incentives to invest more and make the business profitable
- Source of finance
  - Profits after payments can be used to fund expansion
- Indicator of success
  - Profits show that investing can be profitable but losses show that investment must not be made
  - Profit ≠ Cash
- Profit can be in the form of cash, but it can also be in the form of credit (customers will pay later)
- If a company makes 40,000 in sales, but only 20,000 is in cash and the other 20k is in credit. The business only has

20,000 in cash to pay costs.

- Credits can vary from a week to a year, it is ‘promised’ cash but not physical, and can’t pay for costs.
- So, in this case, if the business makes 40,000, and the costs are 15,000 it will make 25,000 in gross profit (theoretical profit), but only 5,000 in net profit

## Understanding Income Statements

- A business account that records all the incomes of a business and all the cost payed over a year – to see if it is making profit.
- It will be used by managers, banks and other investors to see if a business is making profit:
  - To compare with previous years - if it is greater than the year before
  - To see if it is higher than competitors
- The main features of an income statement include:
  - Revenue
  - Costs
  - Gross Profit – the profit made after costs of goods sold are taken away from sales revenue
  - Net Profit (AKA ‘Profit’) – the profit made after taking away all expenses and overhead costs (other expenses)
  - Retained Profit – the net profit after taking away taxes and payments to owners – which is reinvested back into the business

Profit type	Equation
GROSS PROFIT	Sales Revenue – Costs of goods sold
NET PROFIT	Gross Profit – Overhead Costs (wages, electricity, rent, marketing)
RETAINED PROFIT	Net Profit – (tax + dividends)

- Income statements are very important in decision making in a business
- If a business is thinking to relocate a factory, they will make a forecast income statement in both locations and compare

## 5.7. Statement of Financial Position

- Statement of Financial Position** – a document that shows the value of the business’ assets and liabilities in a point in time
- Assets** – Items of value *owned* by a business
- Liabilities** – Debts *owed* by business
- There are 2 types of assets:
  - Current Assets** – (Short-term Assets) Items owned by business for *less* than 1 year i.e. Raw material, cash
  - Non-Current Assets** – (Long-term Assets) Items owned by business for *more* than 1 year i.e. Buildings, land, company cars
- There are also 2 types of liabilities:
  - Current Liabilities** – (Short Term Liabilities) Debts owed by business for less than 1 year i.e. Bank

overdrafts, wages

- **Non-Current Liabilities** – (Long Term Liabilities) Debts owed by business for more than 1 year i.e. Long-term bank loans, creditors (money that business owes to suppliers)
- The **Total Equity** (AKA Shareholders' funds) is how much a business is worth. (only for Limited companies)  
**Shareholders' Funds = Total Assets – Total Liabilities**
- The shareholders' funds is the total amount of money invested in a business by the shareholders/owners
- If the total equity of a business has increased/fallen, the shareholder's stake of the company will be worth more/less, respectively

Format of SOFP

<b>Fixed assets</b>	<b>xxx</b>
Current assets	xxx
Total assets	xxx
<hr/>	
Non current liabilities	xxx
Current liabilities	xxx
Equity:	
Share capital	xxx
Profit/loss account	xxx
Total liabilities + equity	xxx

- From the statement of financial position, you can calculate the Working Capital.  
Working Capital = Current Assets - Current Liabilities
- You can also calculate the Capital Employed – the long-term capital invested in a business  
Capital Employed = Non-Current Assets + Total Equity
- Total Equity = Shareholders' funds

**Interpreting balance sheets**

- Shareholders can see the value of their stake
- They can analyze how expansion is paid for
- Working capital can be calculated
- Working capital = current assets – current liabilities
- Capital employed can be calculated
- Capital employed = shareholders' funds + noncurrent liabilities
- Calculate ratios

**5.8. Analysis of Accounts**

- Using all of the documents and information from cash flow forecasts, balance sheets and income statements you can rate the performance of a business
- Analysis of accounts is interpreting these accounts/documents to see how a business is doing
- To rate a company's performance, you can use 5 ratios
- There are 2 types of ratios:
  - **Profitability Ratios** – how profitable a business is
  - **Liquidity Ratios** – how able a business is to pay its short-term debts (current liabilities)

- Profitability Ratios:
  - **Gross Profit Margin (%)** – how good a company is at converting sales into gross profit. A percentage **GPM (%) = 100 × Gross Profit / Sales Revenue**
  - **Net Profit Margin (%)** – how good a company is at converting sales into net profit. A percentage **NPM (%) = 100 × Net Profit / Sales Revenue**
  - **Return on capital employed** – how profitable a company is compared to the amount of money used  
**RoCE (%) = 100 × Net Profit / Capital Employed**
- One profitability ratio isn't useful by itself. You need to use all the profitability ratios and compare it with previous years of the business.
- Liquidity Ratios:
  - **Current Ratio** – how good a company is to pay off its current liabilities with its current assets **Current Ratio = Current Assets / Current Liabilities**
  - **Acid Test Ratio** – measures the ability of a company to pay off its liabilities without depending on the sales of inventory **Acid Test Ratio =  $\frac{\text{current assets} - \text{inventories}}{\text{current liabilities}}$**
- The acid test ratio is used to measure if a business is likely to survive in the future
- The good and bad values of these ratios:

Gross Profit Margin (%)	No exact value, you must compare with: Competitor businesses, previous years, the targets set by the business
Net Profit Margin (%)	
ROCE (%)	
Current Ratio	Should be <b>above 1.5</b> to be safe
Acid Test Ratio	Should be <b>above 1</b> , unless you are dealing with cash sales in which it can be above 0.75 (cash is liquid - pays of liabilities easily)

- Having lots of stock may mean that the company might be illiquid because inventories are hard to convert to cash easily
- Liquidity is very important for a business:
  - If they can't convert their assets into cash, they won't be able to pay their suppliers (current liabilities)
  - Not paying suppliers will force them to stop trading to pay back their debts

**5.9. Users of accounting information**

- Managers
  - They will have access to much detailed and frequent accounting information
  - They will help them keep control over the performance of each product
  - They will be able to identify which business aspect is doing well and which has a poor performance
  - Help decision making
  - Ratios are a quick way for managers to compare their ratios with other businesses and previous accounts
- Shareholders



- Shareholders and potential investors want to know how big profit/ loss the company has made
- They will want to check the profitability and liquidity ratios and to decide whether shareholders have to buy more shares or not
- They will want to know the worth of the business
- Creditors/ trade payable
  - It will indicate the total value of debts the business has to pay back
  - The cash position of the business
  - Liquidity ratios indicate the ability of the company to pay back its debts
- Banks
  - Risk of illiquid, no lending
- Government
  - To check the tax revenue, whether the firms are paying the right taxes
- Workers and trade unions
  - They will have to want to access whether the future of the company is secure or not
  - Access the profits to help unions improve wages and working conditions of employees
- Other businesses – competitors
  - The managers will compare their profitability and liquidity with other business

**Limitations of accounting records and ratio analysis**

- Managers have access to all accounts data, external users don't have all information
- Ratios are based on past accounting data, may not indicate future performance
- Accounting data over time will be affected by inflation
- Different companies may use different ways of accounting

**6. External influences on business activity**

**6.1. Government Economic Policies & Objectives**

- Governments want 3 main economic objectives:
  - **Low Inflation:** Low prices of goods & services, so people will buy more, more money in economy
  - **Low Unemployment:** High % of people working so that they don't rely on government funds
  - **Economic Growth:** growth of the GDP (Gross Domestic Product) of a country – more goods and services being produced and sold
  - **Balance of payment** (of Imports & Exports): the difference between the imports and the exports of a country balance out (BoP = Exports – Imports)

**Low inflation**

- Inflation – The increase of average prices of goods & services
- Rapid inflation may lead to:
  - A fall in value of money, fall in real incomes
  - Wage price spiral
  - Fall in international competitiveness as prices will be high
  - Businesses may not want to expand and create jobs
  - Living standards will fall
- Low inflation rates will act as an incentive for firms to produce and encourage them to expand

**Low unemployment**

- When people want to and have the ability to work but can't work, then they are said to be unemployed
- Unemployed people don't produce goods and services, output of the country will be lower
- It involves an opportunity cost as government has to pay greater unemployment benefits which could be used improve education and reduce living standards

**Economic growth**

- If an economy's total output rises, it is said to be experiencing economic growth
- GDP is the total value of goods and services produced in an economy
- Economic growth may cause employment to rise, increasing living standards and reducing poverty
- A fall in GDP can lead to:
  - Unemployment
  - Fall in average living standards, as poverty rises
  - Less investment
- Economies go through the 'Business Cycle':

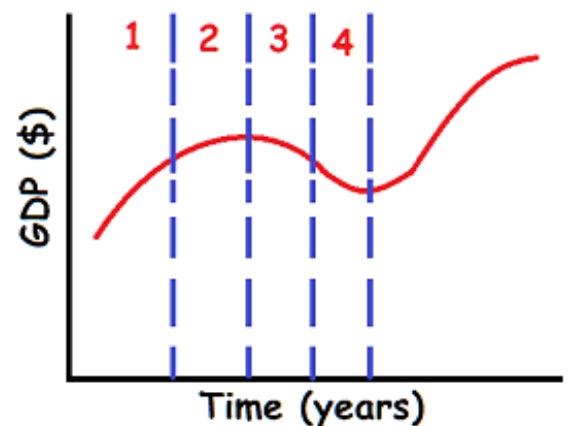

- **Growth:** GDP is rising, unemployment falling, businesses succeeding & higher living standards
- **Boom:** Higher living standards so people start spending more money, so prices increase – business costs will also rise
- **Recession:** people become uncertain about their jobs so they don't spend money. Many workers lose their jobs because of lack of demand & profit in a business

- **Slump** – A long-term, serious recession: Unemployment will be very high, GDP has decreased a lot and many businesses will not survive and go bankrupt

**Balance of Payments**

- Balance of payments is a record of one country's financial transactions internationally
- Governments will aim for equality in balance of payments that is exports equal imports
- Higher imports than exports lead to budget deficit
- Higher exports than imports lead to budget surplus
- Problems of budget deficit: -
  - Government can run out of foreign currency reserves and will have to borrow
  - Exchange rate depreciates – the price of our currency falls as compared to the other currency

**6.2. Government Economic Policies**

- There are 3 main ways governments can influence the economy (AKA economic policies):
  - Government expenditure
  - Changing tax rates
  - Interest Rates
- Government Expenditure is how the government spends the money made from taxes. It is usually spent on education, defense, healthcare, public transport, etc....
- Companies that are involved in these markets/sectors above will benefit. i.e. a bus manufacturing company will benefit if government spends more on public transport
- Spending more on these markets will boost economy in a country (more jobs created, more demand)
- There are 2 types of taxes:
  - **Direct Taxes** – taxes paid directly from incomes (of individuals as wages or as business as revenue)
  - **Indirect Taxes** – VAT, taxes added to prices of goods
- Out of these 2 types, there are 4 common taxes that affect business activity:

Tax	What it is	How it affects business activity
-----	------------	----------------------------------

Tax	What it is	How it affects business activity
<b>Income tax (direct tax)</b>	Tax on people's incomes – \n You can either have a set tax (i.e. 20% of income) or <b>Progressive income tax</b> , where richer people pay higher taxes.	People have less disposable income (money after tax). They would have less money to spend on goods or services. Businesses have less revenue.
<b>Profits Tax (direct tax)</b>	Tax on profits made by businesses (a set percentage)	If tax rates increase: Harder for a business to expand (less profit) less money to reinvest back into business, Fewer people will start their own business
<b>Indirect Tax (VAT)</b>	Tax added to prices of goods & services (varies within types of products)	Prices of goods will increase so less people will buy them – Less demand for a business

Tax	What it is	How it affects business activity
Import Tariffs & Quotas (indirect)	Tax on imported goods from other countries. \n <b>Import Quota</b> is a <i>physical limit to the amount of products that can be imported.</i>	Local businesses will have more demand because there less imported goods, Importing raw materials from abroad will be much more expensive - products will be more expensive - sell less

### 6.3. Interest Rates

- The interest rate is the amount charged for borrowing money from a bank
- In most countries, the interest rates are fixed by the government
- the % of the interest rate is called the monetary policy
- The effects to business activity due to having higher interest rates include:
  - Less profit** for companies that already took out a loan - less/slower **expansion** of a business.
  - Entrepreneurs thinking of starting business might not be able to **afford to take out a loan**
  - If consumer loans (i.e. mortgages) increase, people will have **less disposable income** - **less demand** for goods
  - Higher exchange rates** of currency
- Businesses might respond to all of these policies by:

Policy	Business Response
Higher income tax	Lowering production costs to be able to sell goods for lower prices
Higher tariffs (on imports)	Focusing on the domestic market, Buying materials from local companies rather than from companies abroad
Higher interest rates	Reduce investment for business growth, Lower prices of goods for consumers, Sell assets for cash to reduce loans

### 6.4. Environmental & Ethical Issues

- Business activity can impact the environment in many different ways, including:
  - Air pollution made by factories & transportation
  - Water & land pollution from improper waste disposal
  - Increase carbon emissions - global warming
- Most business decisions lead to benefits and costs. There are **private** and **external** benefits and costs
- Private costs & benefits are costs that a business pays for, and the benefits the business gains
- External Costs** - costs paid by society, rather than the business (as a result of business decision)
- External Benefits** - gains to society, rather than the business (as a result of business decision)
- The possible *external* costs and benefits of a business decision might include:

External Costs	External Benefits
Environment is harmed from waste products	Jobs are created, economy is boosted
Pollution may damage the health of people	Other companies might move in, more services
Less energy	Better infrastructure
Increased traffic	Better living standards

- these externalities change depending on the decision.
- Sustainable development** - development that does not compromise the living standards of future generations
- Businesses can contribute to sustainable development by doing 4 main things:
  - Using **renewable energy** (wind, solar)
  - Recycling** & reusing their **waste**
  - Using **less natural resources** (lean production)
  - Developing **environmentally friendly products & packaging** (i.e. biodegradable packaging)
- People & consumers pressure companies to think more environmentally. There are many reasons and ways businesses give the environment a higher priority:
  - Pressure groups - a group of people who want to change policies/decisions of businesses or the government.
  - Pressure groups acting on unethical decisions made by a business will lead to a **consumer boycott** - consumers not buying their products
  - Environmentally friendly businesses can use the fact that they are environmental as a marketing advantage

Type of pressure	What it is	How and why it responds
------------------	------------	-------------------------

Type of pressure	What it is	How and why it responds
Pressure group	a group of people who want to change policies / decisions of businesses They lead to <b>consumer boycotts</b> - consumers not buying their products	Lots of public support, Very bad brand image & reputation, Loss in sales
Laws passed by Government	Government making certain activities illegal (i.e. dumping waste)	It is more expensive to manufacture
Fines	If a business produces more pollution than the government allows, they pay heavy fines.	Costs of business increase

- Governments sell 'permits' to companies that allow it to pollute the environment up to a certain level
- Firms that pollute *less* than the government allows, can sell their permit to companies that pollute more
- This motivates businesses to pollute less, to earn money
- **Ethics** - "doing the right thing" - the moral principles
- Most businesses have to face many ethical decisions, they have to decide whether to act ethically or have higher profits
- Unethical decisions include:
  - Employing child workers, even though it might not be illegal in some countries
  - Buying supplies that lead to damage of the environment
  - Paying managers large bonuses while having their workers in minimum wage & poor conditions
  - Offering bribes to people to gain information
- Different companies have different ethical standards because people have different moral codes
- Businesses may respond to ethical issues by following their moral code and "doing the right thing"
- These decisions have benefits and disadvantages:

Benefits	Disadvantages
Consumers appreciate the efforts made by the company and so they buy more from them	Higher costs of production
Creates good publicity	Higher prices - might lead to less demand
Less risk of lawsuits	In some places families depend on their children to earn money

Benefits	Disadvantages
Easier to find workers	

## 6.5. Business and the International Economy

- **Globalization** -the world becoming more interconnected leading to increasing worldwide trade & people moving
- The reasons for globalization include:
  - More **Free-Trade Agreements** - imports/exports between countries that pay no tariffs
  - Easier, cheaper and faster transportation between countries
  - E-commerce allows products to be bought from all over the world
  - Industrializing countries (i.e. India & China) can produce products at very low prices
- The opportunities and threats of globalization to a business include:

Opportunities	Threats
Businesses can sell abroad, increasing sales	Increasing foreign competitors importing their products, leading to less sales (& profit)
Opening factories or offices abroad - can be cheaper to produce, but it is expensive to set up	Workers in home country might leave for higher wages in other countries
Importing materials from abroad - can be cheaper but transport costs can be too high	More foreign companies set up operations in the home country of the business, more competition
Importing goods from abroad and selling it in home country	

- Sometimes governments introduce import tariffs and quotas to protect local businesses - this is called **Protectionism**
- They believe that by reducing the number of foreign competitors and goods (that would have much lower prices), there will be less unemployment and higher incomes
- However, by doing this, it is harder for local businesses to import materials and export their goods abroad

## 6.6. Multinational Companies (MNCs)

- Multinational Company = Transnational Company
- A multinational company is a company that has factories or service operations in more than one country
- *It is not just selling products abroad*, it is having operations abroad
- The benefits of a business becoming international:

Benefits to the business	Benefits to the country
Producing goods at lower costs	Jobs are created
Closer to resources (i.e. oil)	Investments in development of infrastructure in country
Closer to market	More exports
Avoid expensive taxes of import of goods (i.e. Korean cars (KIA) being produced in EU to benefit from free trade)	Tax – more money to government
Spread risks (if there are low sales in one country and high sales in another)	Increased product choice for consumers

- However, there are potential drawbacks to the country:
  - Less sales for local businesses, might go bankrupt
  - 'Repatriation of profits' – profits are sent back to home country and doesn't benefit country located
  - Business has lots of influence on government – they can threaten to leave the country
  - They can use up scarce resources in the country

### 6.7. Exchange Rates

- **Exchange Rate** – the price of one currency in terms of another currency
- For example, 1 Euro is equivalent to 1.2 Dollars
- **Currency Appreciation** – when the value of a currency increases (i.e.  $1\text{€} = 1.2\text{\$} \rightarrow 1\text{€} = 1.7\text{\$}$ ) - it can buy more of another currency
- **Currency Depreciation** – when the value of a currency decreases

(i.e.  $1\text{€} = 1.2\text{\$} \rightarrow 1\text{€} = 1.1\text{\$}$ ) – it can buy less of another currency

- The exchange rate of a currency is influenced by 2 things:
  - **Demand for the currency:** if many people want to buy the currency the price will increase because there is a 'limited' number of currency (appreciate)
  - **Supply of currency:** if the central bank prints more money, the supply increases but the demand is still the same so the value is lower (depreciation)
- Exchange rates can affect businesses by:

If it Appreciates:	If it Depreciates:
<b>Import prices fall:</b> since your currency can buy more of the other currency	<b>Import prices rise:</b> your currency is worth less so you need more to buy other currencies
<b>Export prices rise:</b> your currency is worth more so it is more expensive for other currencies to buy it	<b>Export prices fall:</b> it is worth less so other currencies can buy your currency for less of theirs

- This means that if the currency Appreciates:
  - The product's **price** in other countries will **increase**
  - Business will make **more profit**
  - Business can lower the price and still make the same amount of money as before – it is **more competitive**
- If the currency depreciates:
  - The products **price** in other countries will **decrease**
  - **less profit** will be made
  - Business needs to raise the price to make the same amount of money as before – **less competitive**